

Operator's manual



TruTool C 160 (1A1), (1B1)

english

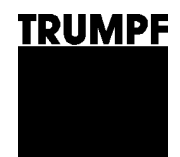

Table of contents

1.	Safety	3
1.1	General safety rules.....	3
1.2	Specific safety rules.....	4
2.	Description	5
2.1	Correct use	6
2.2	Technical data	7
3.	Tool assembly.....	8
3.1	Cutting parallel strips	8
3.2	Selection of tools	9
4.	Operation.....	10
4.1	Working with the TruTool C 160.....	10
	Separating chips.....	11
5.	Maintenance	12
5.1	Replacing the TruTool C 160 (1A1).....	13
	Replacing the cutter.....	14
	Turning or replacing the insertable cutters	14
5.2	Replacing the TruTool C 160 (1B1).....	15
	Replacing the cutter.....	15
	Turning or replacing the insertable cutters	17
5.3	Replacing carbon brushes	18
6.	Original accessories and wearing parts.....	19

Guarantee

Replacement parts list

Addresses

1. Safety

1.1 General safety rules

USA/CAN ➤ Read the Operator's Manual and the general safety rules (Material number 1239438, red document) in their entirety before starting up the machine. Follow precisely the directions contained therein.

Rest of the world ➤ Read the Operator's Manual and safety instructions (Material number 125699, red document) in their entirety before starting up the machine and Follow precisely the directions contained therein.

➤ The safety regulations according to DIN VDE, CEE, AFNOR and other regulations which are valid in individual countries should be adhered to.



Danger

Lethal danger due to electric shock!

- Remove the plug from the plug socket before undertaking any maintenance work on the machine.
 - Check the plug, the cable and the machine for damage each time before the appliance is used,.
 - Keep the machine dry and do not operate in damp rooms.
 - When using the electric tool outside, connect the fault current (FI) protective switch with a maximum breaking current of 30 mA.
-



Warning

Danger of injury due to improper handling!

- When working with the machine, wear safety glasses, hearing protection, protective gloves and work shoes.
 - Do not plug in the plug unless the machine has been switched off. Pull out the mains plug after use.
-

1.2 Specific safety rules



Warning

Risk of injury to the hands!

- Do not place your hand into the processing line.
-



Caution

Damage to property due to improper handling!

The machine will be damaged or destroyed.

- Do not use the power cord to carry the machine.
 - Always guide the electric cord away from the back of the machine and do not pull it across sharp edges.
 - Arrange for start-ups and checks on manual electric tools to be carried out by a trained specialist. Only used the original accessories provided by TRUMPF.
-

2. Description

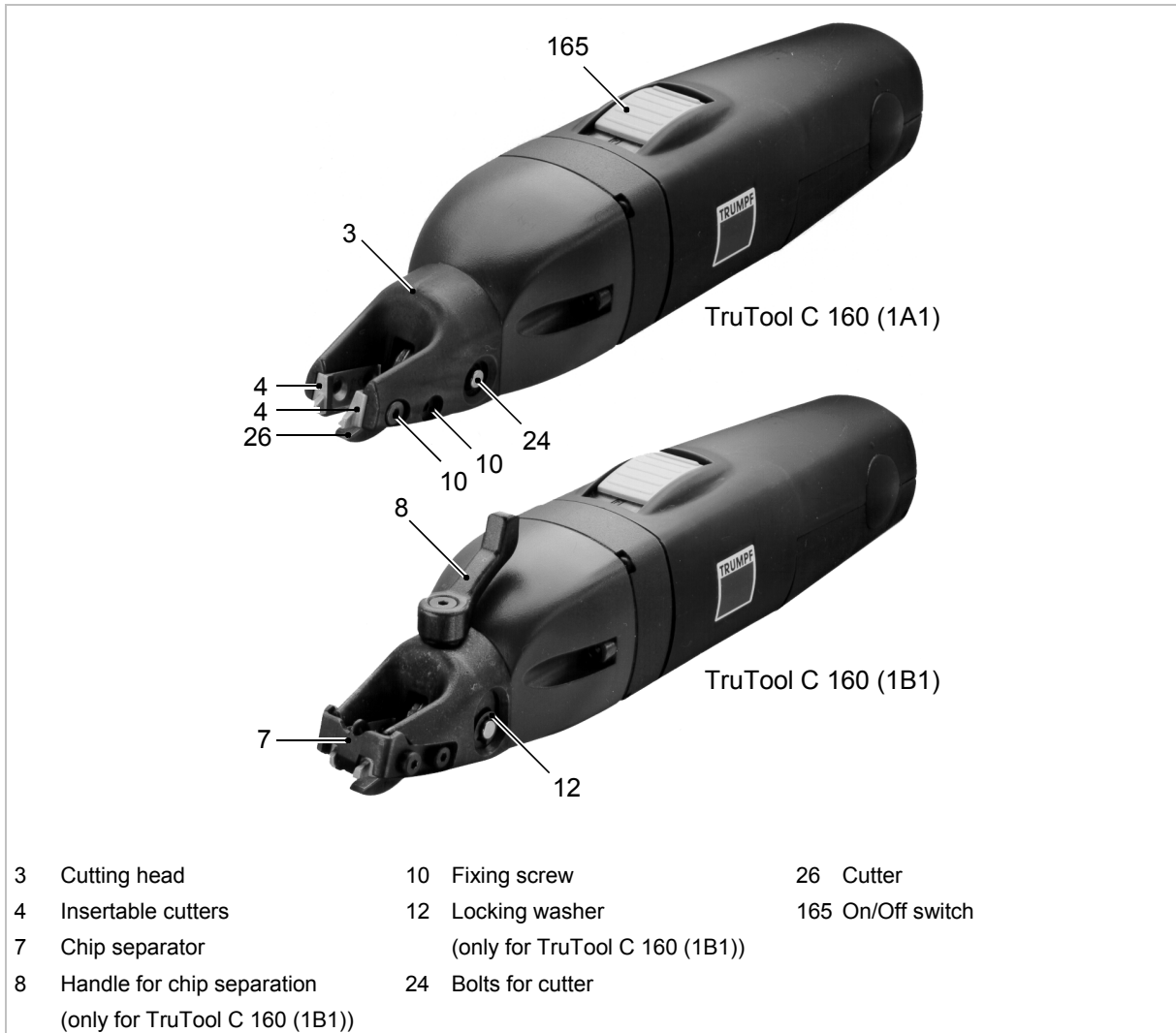

Slotting shears TruTool C 160 (1A1) and TruTool C 160 (1B1)

Fig. 54354

2.1 Correct use



Warning

Risk of injury!

- Use machine only for the processing and materials which are described under "Correct use".

The TRUMPF TruTool C 160 slotting shears are an electric hand tool used for the following applications:

- Slitting of plate-shaped workpieces made of steel, aluminum, plastic, etc.
- Slitting straight or curved exterior and interior cutouts.
- Slitting along scribed lines.

The TRUMPF TruTool C 160 (1B1) also offers the option of cutting cutting away chips which are produced while machining within the workpiece as required.

2.2 Technical data

	Rest of the world			USA
	Values	Values	Values	Values
Voltage	230 V	120 V	110 V	120 V
Frequency	50/60 Hz	50/60 Hz	50/60 Hz	50/60 Hz
Operating speed	6-10 m/min	6-10 m/min	6-10 m/min	20-33 ft/min
Nominal take-up power	350 W	350 W	350 W	350 W
Stroke rate with idle run	5800/min	6600/min	6200/min	6600/min
Weight	1.4 kg	1.4 kg	1.4 kg	3.1 lbs
Start hole diameter	8 mm (Cr)	8 mm (Cr)	8 mm (Cr)	0.32 in (Cr)
	15 mm (straight cutter)	15 mm (straight cutter)	15 mm (straight cutter)	0.6 in (straight cutter)
Smallest radius with curved cuts	40 mm (curve cutter)	40 mm (curve cutter)	40 mm (curve cutter)	1.57 in
	90 mm (straight cutter)	90 mm (straight cutter)	90 mm (straight cutter)	3.5 in
	160 mm (Cr)	160 mm (Cr)	160 mm (Cr)	6.3 in
Protective insulation	Class II	Class II	Class II	Class II

Technical data

Table 1

	Permitted material thicknesses		
	Steel up to 400 N/mm ²	Steel up to 600 N/mm ²	Aluminum 250 N/mm ²
Straight cutter	1.6 mm (0.063 in)	1.2 mm (0.048 in)	2.0 mm (0.075 in)
Curve cutter	1.0 mm (0.039 in)	0.8 mm (0.031 in)	1.2 mm (0.048 in)
Cutter Cr	1.6 mm (0.063 in)	1.2 mm (0.048 in)	2.0 mm (0.075 in)

Table 2

Noise and vibration	Measured values in accordance with EN 50144
A-weighted sound level	Typically 79 dB (A)
A-weighted acoustic power level	Typically 85 dB (A)
Hand-arm vibration	Typically less than or equal to 2.5 m/s ²

Measured values for noise and vibration

Table 3

Note

The measured values specified above may be exceeded while working.

3. Tool assembly

3.1 Cutting parallel strips

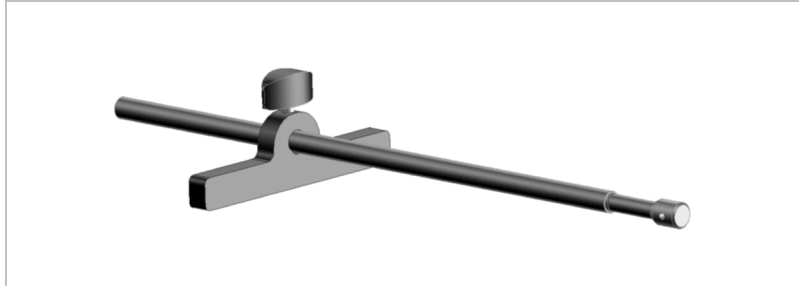

Parallel stop

Fig. 17756

The parallel stop can be used to process parallel strips 35-300 mm wide.

1. Remove the bolts for the cutter.
2. Mount the parallel stop.

The rod of the parallel stops adopts the function of the cutter bearing arrangement.

3.2 Selection of tools

Note

The cutters have 2 cutting edges. These cannot be reshaped.

Different types of cutter are required according to the thickness or tensile strength of the workpiece. (see Table 4, Pg. 9)

Note

If the cutter is not selected as specified,

- The quality of cut will be severely impaired.
- If the feed power increases significantly.
- The cutter will break.

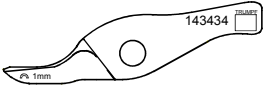
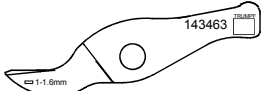
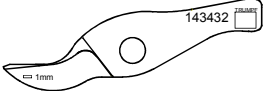
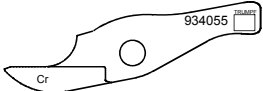
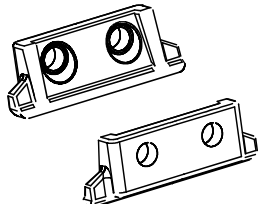
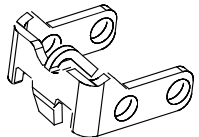
Tool type	Designation	Order No.	Sheet thickness (mm)
	Curve cutter 1.0 mm	143434	Aluminum max. 250 N/mm ² 0.3 to 1.2 Steel max. 400 N/mm ² 0.3 to 1.0 Stainless steel max. 600 N/mm ² 0.3 to 0.8
	Straight cutter 1.0 - 1.6 mm	143463	Aluminum max. 250 N/mm ² 1.0 to 2.0 Steel max. 400 N/mm ² 1.0 to 1.6 Stainless steel max. 600 N/mm ² 0.8 to 1.2
	Straight cutter 1.0 mm	143432	Aluminum max. 250 N/mm ² 0.3 to 1.2 Steel max. 400 N/mm ² 0.3 to 1.0 Stainless steel max. 600 N/mm ² 0.3 to 1.0
	Cutter Cr	934055	Aluminum max. 250 N/mm ² 1.0 to 2.0 Steel max. 400 N/mm ² 1.0 to 1.6 Stainless steel max. 600 N/mm ² 0.8 to 1.2
	Insertable cutters (1 set = 2 pieces) with screws	For TruTool C 160 (1A1): 927708 For TruTool C 160 (1B1): 913520	All materials
	Chip separator TruTool C 160 (1B1)	143950	All materials

Cutter selection

Table 4

4. Operation



Caution

Damage to property possible due to too-high network voltage!

Damage to the motor

- Check the power supply. The power supply must correspond to the information on the machine type plate.



Warning

Danger of injury possible due to improper handling!

- When working with the machine, always ensure that it has a secure base.
- Never touch the tool while the machine is running.
- Always guide the machine away from the body while working.
- Do not work holding the machine above your head.

4.1 Working with the TruTool C 160

Switching on

- Move the On/Off switch to the front.

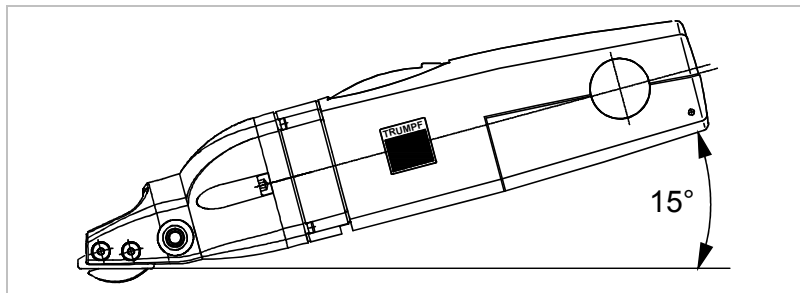

Fig. 17562

- Move the machine forward at an angle of about 15° to the sheet surface.

Note

Do not burden the machine to such an extent that it comes to a standstill.

For safe operation and a good cut performance:

- Ensure that cutters are sharp.
- Turn insertable cutters when it is time to do so.
- Replace insertable cutters when it is time to do so.

The following specifications apply when cutting radiuses:

- Do not tilt the machine.
- Proceed with a low feed rate.

Separating chips



Caution

Damage to property from interrupted chip brake!

The machine may no longer be used.

- Replace the chip separator.

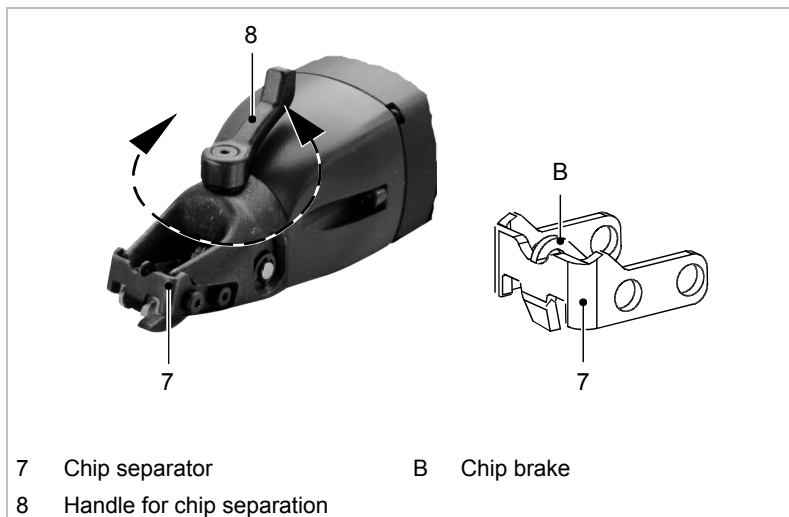

Fig. 17626

1. Separate the chips: turn the handle by a 3/4 clockwise rotation while the machine is running.
2. Continue the operating procedure: turn the handle to the starting position.

- Switching off** ➤ Move the On/Off switch to the rear.

Note

Do not move the machine towards the workpiece until full speed has been reached.

5. Maintenance



Warning

Risk of possible injury due to improper repairs!

The machine does not function properly.

- Repairs should be carried out only by a trained specialist.

Maintenance point	Procedure and time interval	Recommended lubricants	Order No. Lubrication agents
Bolts	Lubricate when replacing cutter	"G1" lubricating grease	139440
Cutter	Lubricate when replacing cutter	"G1" lubricating grease	139440
Gearbox and gear head (2)	After 300 operating hours, arrange for a trained specialist to relubricate or to replace the lubricating grease.	"G1" lubricating grease	139440
Insertable cutters	Turn as needed	-	-
Insertable cutters	Replace as needed	-	-
Cutter	Replace as needed	-	-

Maintenance Table

Table 5

5.1 Replacing the TruTool C 160 (1A1)



Danger

Possible lethal danger due to electric shock!

- Pull the plug out of the socket when carrying out tool changes and before all maintenance work on the machine.

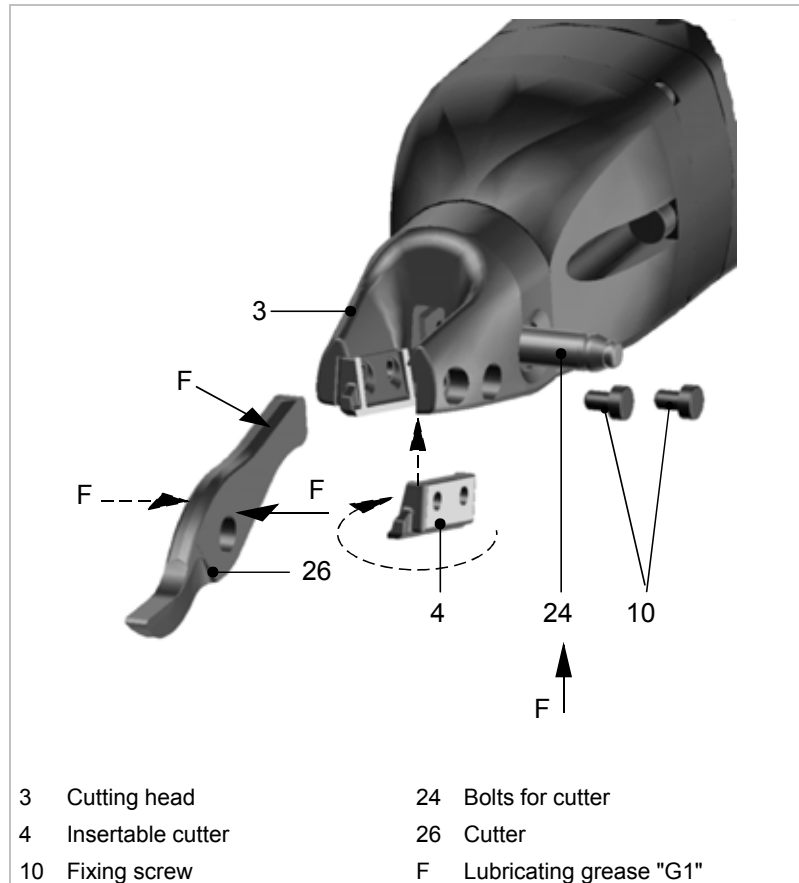

Changing the tool

Fig. 17576

Replacing the cutter



Caution

Damage to property possible due to blunt tools!

Overloading of the machine.

- Check the cutting edge of the cutting tool hourly for wear. Sharp cutters provide good cutting performance and are easier on the machine. Replace cutters promptly.
-

When both cutting edges of an insertable cutter are blunt, replace the cutter.

1. Press out the bolt which has locked into place.
2. Pull the cutter out of the cutting head.
3. Lightly grease the new cutter and the bolt.
4. Insert the new cutter.
5. Push the bolt into the bore hole until it locks into place.

Turning or replacing the insertable cutters

1. Unscrew the fixing screws.
2. Check the insertable cutters:
 - When a cutting edge is blunt, turn the insertable cutters 180°.

or

 - When both sides of the cutting edges of an insertable cutter are blunt, replace both insertable cutters.
3. Tighten the fixing screw.

5.2 Replacing the TruTool C 160 (1B1)



Danger

Possible lethal danger due to electric shock!

- Pull the plug out of the socket when carrying out tool changes and before all maintenance work on the machine.

Replacing the cutter



Caution

Damage to property possible due to blunt tools!

Overloading of the machine.

- Check the cutting edge of the cutting tool hourly for wear. Sharp cutters provide good cutting performance and are easier on the machine. Replace cutters promptly.

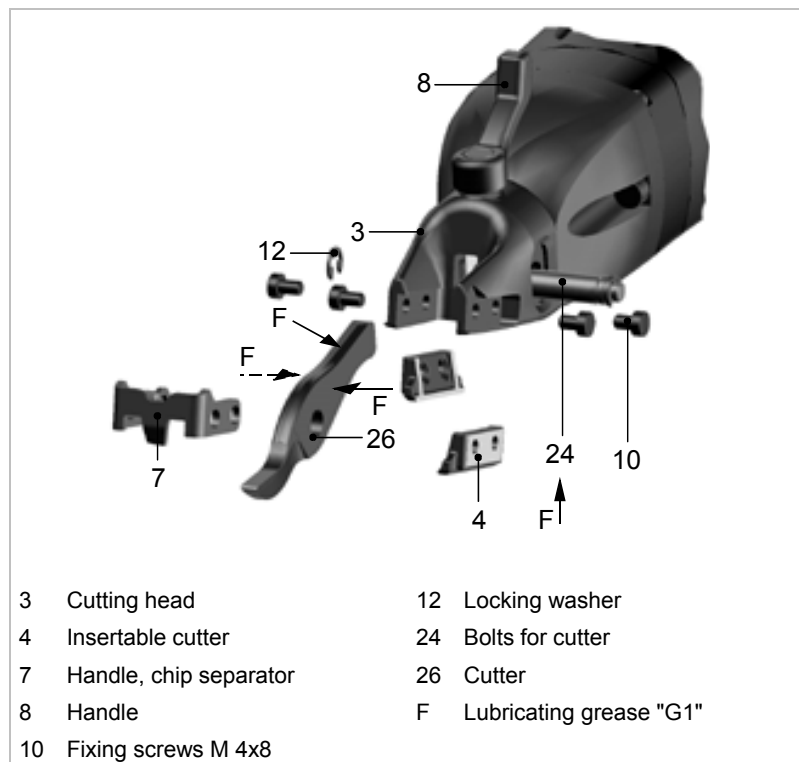

Fig. 17577



When both cutting edges of an insertable cutter are blunt, replace the cutter.

1. Remove the locking washer using a screwdriver.
2. Push out the bolt.
3. Pull the cutter out of the cutting head.
4. Lightly grease the bolt and the new cutter.
5. Insert the cutter.
6. Push the bolt through the bore hole of the cutter until it reaches the stop.
7. Insert the locking washer into the specified notch of the bolt.

Turning or replacing the insertable cutters

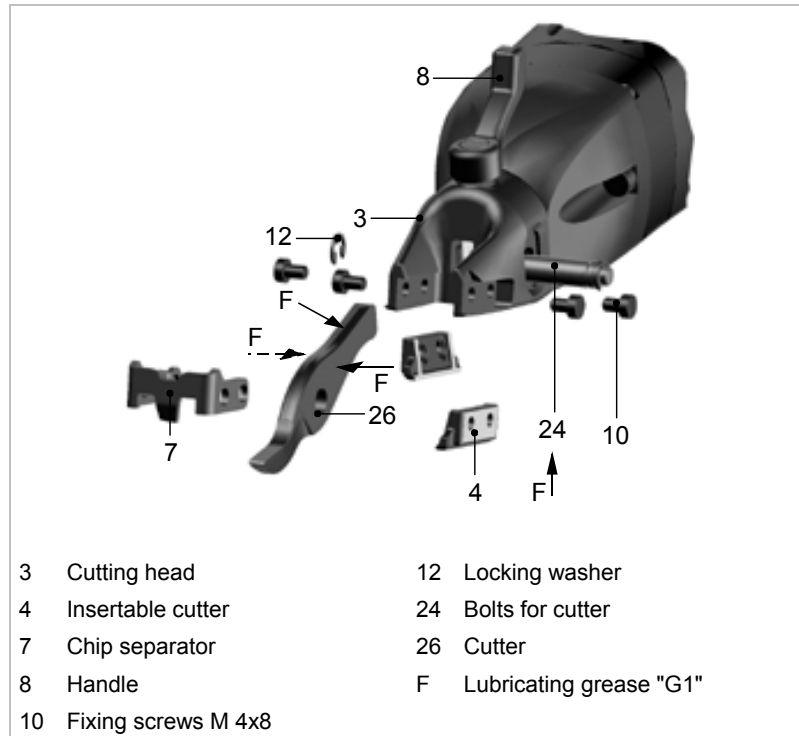

Fig. 17577

1. Unscrew the fixing screws.
2. Check the insertable cutters:
 - When a cutting edge is blunt, turn the insertable cutters 180°.

or

 - When both sides of the cutting edges of an insertable cutter are blunt, replace both insertable cutters.
3. Turn the handle by a $\frac{3}{4}$ rotation to the right, in order to bring the cutter into the cutting position.
4. Push the chip separator onto the cutting head until the chip separator is positioned over the front edge of the cutter.
5. Hold down the chip separator and insertable cutters in this position.
6. Tighten the fixing screw.
7. Turn the handle to the left to the working position.

5.3 Replacing carbon brushes

The motor comes to a standstill when the carbon brushes are worn out.

- Have the carbon brushes checked and replaced as needed by a trained technician.

Note

Only use original replacement parts and take note of the information on the rating plate.

6. Original accessories and wearing parts

	Original accessories	Wearing parts	Options	Material No.
Insertable cutters for TruTool C 160 (1A1) (1 set = 2 pieces) with screws		+		927708
Insertable cutters for TruTool C 160 (1B1) (1 set = 2 pieces) with screws		+		913520
Straight cutter -1-1.6 mm		+		143463
Straight cutter -1 mm		+		143432
Curve cutter		+		143434
Cutter Cr (For processing high-tensile sheets)		+		934055
Chip separator (Only for TruTool C 160 (1B1))		+		143950
1 Straight cutter -1-1.6 mm	+			143463
2 Insertable cutters 1 chip separator (only for TruTool C 160 (1B1))	+			143950
Allen key DIN 911-2,5	+			067822
Operator's manual	+			949067
Safety information (red document), other countries	+			125699
Safety information (red document), USA	+			1239438
Parallel stop			+	143439
Lubricating grease "G1" tube (25 g)			+	344969
Lubricating grease "G1" can (900 g)			+	139440

Tab. 6

Ordering wearing parts To ensure fast and sure delivery of original and wearing parts:

1. Give the order number.
2. Enter further order data:
 - Voltage data.
 - Number of pieces.
 - Machine type.
3. Specify complete shipping information:
 - Correct address.
 - Required delivery type (e.g. air mail, courier, express mail, ordinary freight, parcel post).
4. Send the order to the TRUMPF representative office. For TRUMPF service addresses, see the address list at the end of the document.

