

# Operating manual



## TruTool S 114 (1A1)

---

english



# Table of Contents

<b>1.</b>	<b>Safety .....</b>	<b>3</b>
1.1	General safety information.....	3
1.2	Specific safety information.....	4
<b>2.</b>	<b>Description .....</b>	<b>5</b>
2.1	Intended use .....	5
2.2	Technical specifications.....	6
<b>3.</b>	<b>Setting work .....</b>	<b>6</b>
<b>4.</b>	<b>Operation .....</b>	<b>7</b>
4.1	Operating the TruTool S 114 .....	8
4.2	Cutting tubes.....	9
4.3	Trimming sheets .....	10
4.4	Cutting profiles.....	11
<b>5.</b>	<b>Maintenance .....</b>	<b>12</b>
5.1	Turning or replacing tools .....	13
5.2	Replacing carbon brushes .....	14
<b>6.</b>	<b>Original accessories and wearing parts.....</b>	<b>15</b>

**Guarantee**

**Replacement parts list**

**Addresses**

---

## 1. Safety

### 1.1 General safety information

**USA/CAN** ➤ Read the operating manual and the safety information (material no. 1239438, red document) completely before putting the machine into service. Follow the instructions strictly.

**Other countries** ➤ Read the operating manual and the safety information (material number 125699, red document) completely before putting the machine into service. Follow the instructions strictly.

➤ Comply with the safety regulations in accordance with DIN VDE, CEE, AFNOR as well as any other regulations that apply in the individual countries.



**Danger**

---

#### **Risk of fatal injury from electric shock!**

- Pull the plug from plug socket before undertaking any maintenance work at the machine.
  - Check the plug, cable and machine for damage each time before using the machine.
  - Keep the machine dry and do not operate it in damp rooms.
  - Connect the earth leakage (EL) circuit breaker with a maximum release current of 30 mA when using the electric tool outside.
- 



**Warning**

---

#### **Danger of injury due to improper handling!**

- Wear safety glasses, hearing protection, protective gloves and work shoes when working at the machine.
  - Do not insert the plug unless the machine is switched off. After use, pull out the power plug.
-

---

## 1.2 Specific safety information

---



Warning

---

### **Risk of injury to hands!**

- Do not reach into the processing line with your hands.
  - Do not reach into the space between the oscillating lever and the abrasive cutting head with your hands or fingers.
- 



Caution

---

### **Damage to property due to improper handling!**

#### **Machine will be damaged or destroyed.**

- Do not use the power cable to carry the machine.
  - Always position the cable leading away from the machine, at back of the machine. Do not pull the cable over sharp edges.
  - Have servicing and inspections of hand-held electric tools carried out by a qualified specialist. Only use original accessories provided by TRUMPF.
-

## 2. Description

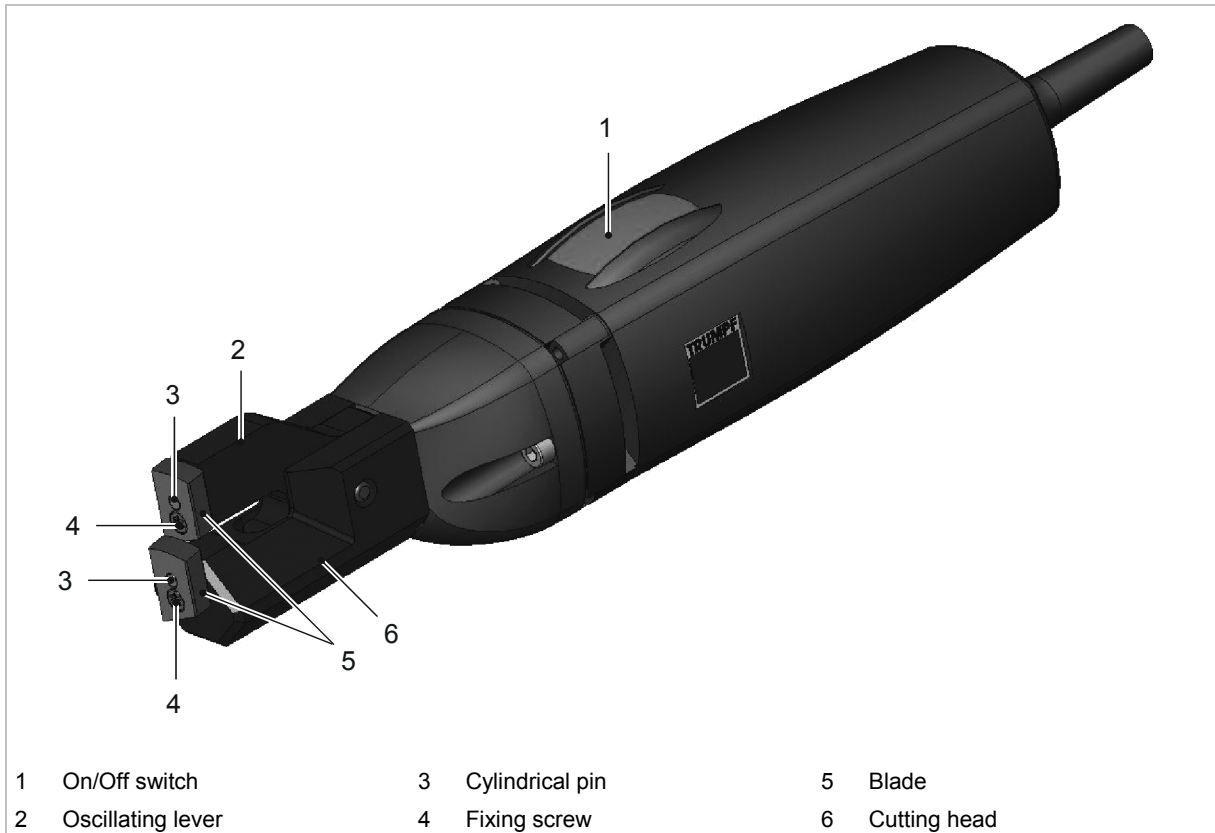

Trimming shears TruTool S 114

Fig. 46781

### 2.1 Intended use



Warning

#### Danger of injury!

- Only use the machine for work and materials as described under "Intended use".

The TRUMPF TruTool S 114 trimming shear is an electrical, hand-held device used for the following applications:

- Cutting plate-shaped workpieces made of steel, aluminum, plastic, etc.
- Cutting plate-shaped workpieces made of steel, aluminum, plastic, etc.

## 2.2 Technical specifications

	Other countries			USA
	Values	Values	Values	Values
<b>Voltage</b>	230 V	120 V	110 V	120 V
<b>Frequency</b>	50/60 Hz	50/60 Hz	50/60 Hz	50/60 Hz
<b>Working speed</b>	4-6 m/min	4-6 m/min	4-6 m/min	13-20 ft/min
<b>Nominal take-up power</b>	350 W	350 W	350 W	350 W
<b>Idle stroke rate</b>	5800/min	6600/min	6200/min	6600/min
<b>Min. curve radius</b>	60 mm	60 mm	60 mm	2.36 in
<b>Max. trimming width</b>	30 mm	30 mm	30 mm	1.18 in
<b>Weight</b>	1.9 kg	1.9 kg	1.9 kg	4.2 lbs
<b>Protective insulation</b>	Class II	Class II	Class II	Class II

Technical data

Table 1

	Permissible material thickness		
	Steel up to 400 N/mm <sup>2</sup>	Steel up to 600 N/mm <sup>2</sup>	Aluminum 250 N/mm <sup>2</sup>
<b>Standard blade</b>	1.6 mm (0.063 in)	1.0 mm (0.039 in)	2.0 mm (0.079 in)

Table 2

Noise and vibration	Measured values according to EN 60745
A-class sound pressure level	Typically 79 dB (A)
A-class acoustic power level	Typically 85 dB (A)
Hand-arm vibration	Typically less than or equal to 2.5 m/s <sup>2</sup>

Measured noise and vibration values

Table 3

### Note

The measured values specified above may be exceeded while working.

## 3. Setting work

No settings on the machine are necessary.

---

## 4. Operation



Caution

---

### Damage to property due to high power-supply voltage!

#### Motor damage.

- Check the power supply voltage. The power-supply voltage must correspond to the information on the nameplate of the machine.
- 



Warning

---

### Risk of injury to hands!

- Do not reach into the processing line with your hands.
  - Do not reach into the space between the oscillating lever and the abrasive cutting head with your hands or fingers.
- 



Warning

---

### Danger of injury due to improper handling!

- Make sure the machine is in a stable position when operating it.
  - Never touch the tool while the machine is running.
  - Always operate the machine away from your body.
  - When working with the machine, wear safety glasses, protective gloves and work shoes.
- 

### Note

Waste metal may arise when machining tubes, profiles and sheets, which may then become entangled on the abrasive cutting head. Therefore one should cut tubes in stages and trim sheets in stages.

## 4.1 Operating the TruTool S 114

### Note

Do not subject the machine heavy loads to such an extent that it stops.

To protect the machine and for a good cutting performance:

- Ensure that blades are sharp.
- Replace the blades in due time.

**Switching on the machine** ➤ Shift the On/Off switch forwards.

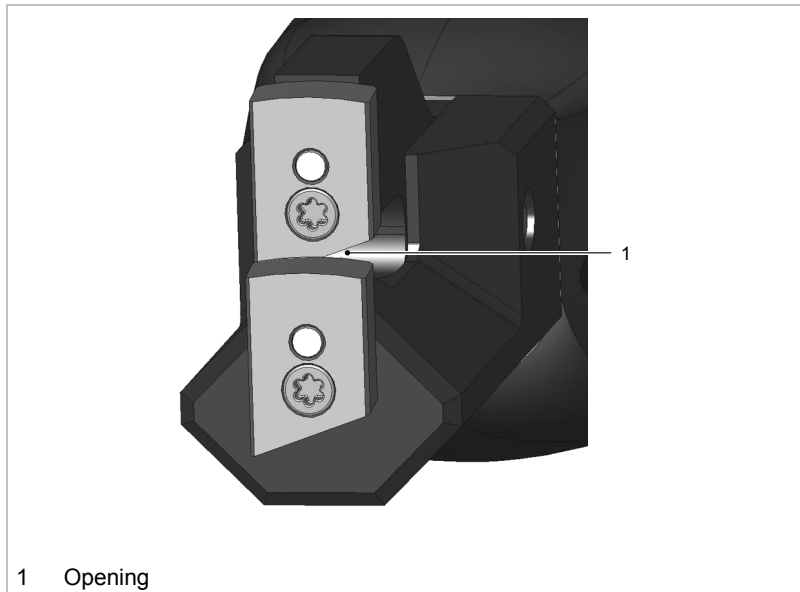
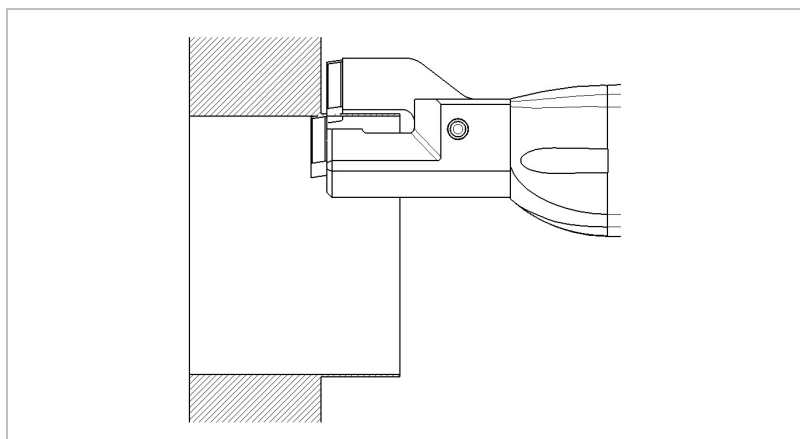

Fig. 46785



Lateral view

Fig. 46857

**Switching off the machine** ➤ Shift the On/Off switch to the rear.



## 4.2 Cutting tubes

1. Place the machine opening around the tube material.



Fig. 46787

2. Lead the machine diagonally across the tube/sheet.

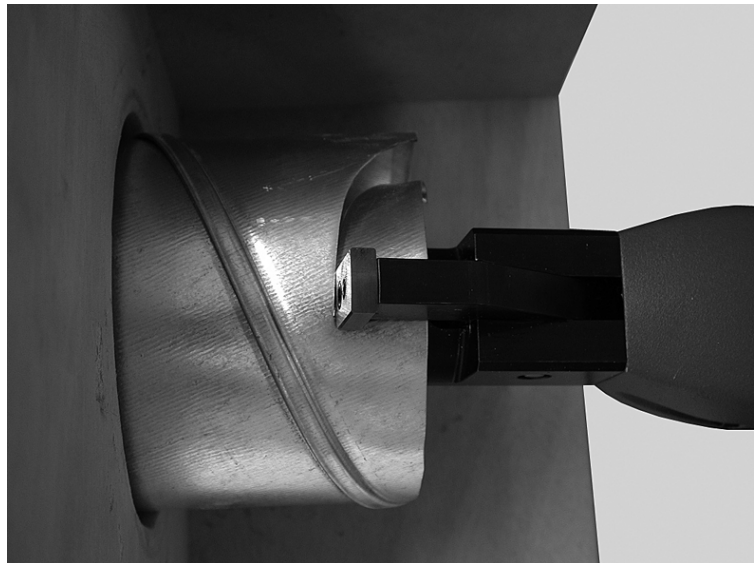

Fig. 46784

3. Straighten the machine by means of a swiveling motion.

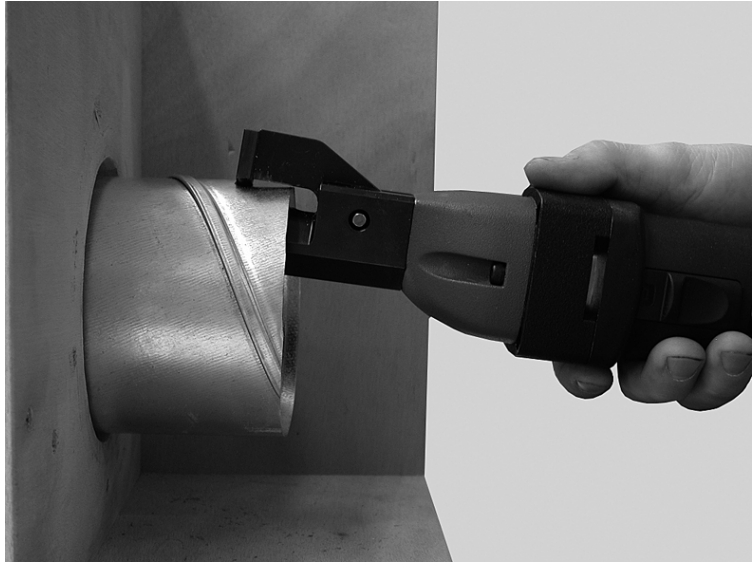

Fig. 46786

4. For a slightly tapered end to the pipe, lean the machine slightly towards the center of the tube.

**Note**

Inclination of the machine prevents the oscillating lever damaging the walls.

### 4.3 Trimming sheets

- Similar procedure as when cutting tubes.

## 4.4 Cutting profiles

- When cutting profile tubes, for example, always place the oscillating lever on the side of the inner radius.

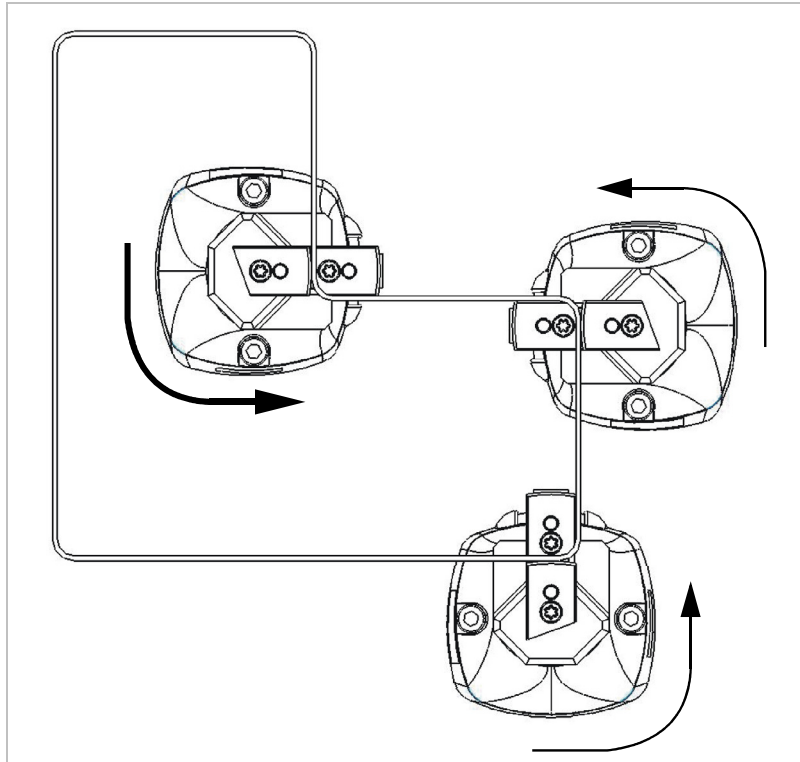

Direction of cutting

Fig. 46858

### Note

If profile tubes are cut without a corner radius, deformation of the tube will occur close to the corners. To reduce this deformation to a minimum, there must be a minimum inner radius of 5 mm.

## 5. Maintenance



Warning

**Danger of injury due to the repair work not being carried out properly!**

**Machine does not work properly.**

- Repair work may only be carried out by a qualified specialist.

Maintenance point	Procedure and interval	Recommended lubricant	Order no. Lubricant
Bolt	Have a specialist either lubricate again or replace the lubricating grease every 300 operating hours.	Lubricating grease "G1"	0139440
Oscillating lever	Have a specialist either lubricate again or replace the lubricating grease every 300 operating hours.	Lubricating grease "G1"	0139440
Gearbox and gear head	Have a specialist either lubricate again or replace the lubricating grease every 300 operating hours.	Lubricating grease "G1"	0139440
Blade	Replace as necessary	-	-

Maintenance table

Table 4

## 5.1 Turning or replacing tools



**Danger**

### Risk of fatal injury from electric shock!

- Pull the plug out of the socket whenever tools have to be replaced or prior to maintenance work on the machine.



**Caution**

### Material damage by blunt tools!

#### Machine overload.

- Check the cutting edge of the blade hourly for wear. Sharp blades ensure good cutting quality and help protect the machine. Change or replace the blades in due time.

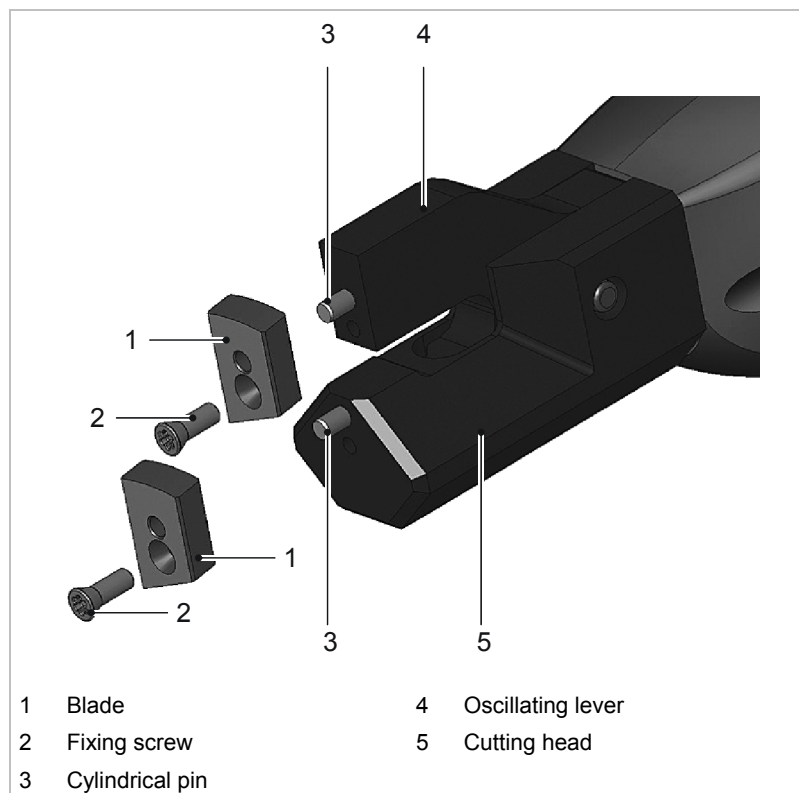

Swapping the tool

Fig. 46788

### Swapping or replacing tools

The blades have two cutting edges and can be swapped.

1. Undo the fixing screws.
2. Pull the blade away from the cylindrical pin.
3. Clean the support area.

- 
4. Check the drilling depth:
    - If all cutting edges of the two blades are blunt: Insert new blades.

**or**

    - If only one of the cutting edges is blunt: Swap the blades (oscillating lever and abrasive cutting head).
  5. Place the blade closest to the oscillating lever onto the cylindrical pin.
  6. Place the blade closest to the abrasive cutting head onto the cylindrical pin.
  7. Tighten the fixing screws.

## 5.2 Replacing carbon brushes

The motor comes to a standstill when the carbon brushes are worn out.

- Have the carbon brushes checked and replaced as required by a qualified specialist.

### **Note**

Only use original replacement parts and observe the information on the rating plate.

## 6. Original accessories and wearing parts

Designation	Supplied original accessories	Wearing part	Options	Order no.
Blades (2x)		+		1376494
Lubricating grease "G1" can (900 g)			+	139440
Operating manual	+			1381721
Safety information (red document), other countries	+			1239438
Safety information (red document), USA	+			125699
System case	+			0345243
Torx screwdriver	+			0359907

Table 5

- Ordering wearing parts** To ensure the correct and fast delivery of original parts and wearing parts:
1. Specify the order number.
  2. Enter further order data:
    - Voltage data
    - Quantity
    - Machine type
  3. Provide complete shipping information:
    - Correct address.
    - Desired delivery type (e.g. air mail, courier, express mail, ordinary freight, parcel post).
  4. Send the order to the TRUMPF representative office. For TRUMPF service addresses, see the address list at the end of the document.

