

Operator's manual



TruTool N 500 (2A1)

TRUMPF GmbH + Co. KG, Technische Redaktion
Johann-Maus-Straße 2, D-71254 Ditzingen
Fon: +49 7156 303 - 0, Fax: +49 7156 303 - 930540
Internet: <http://www.trumpf.com>
E-Mail: docu.tw@de.trumpf.com

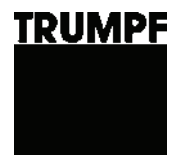

Table of contents

1	Safety	2
1.1	General safety information	2
1.2	Specific safety information for nibbler	2
2	Description	4
2.1	Intended use	4
2.2	Technical data	5
2.3	Icons	5
2.4	Noise and vibration information	6
3	Setting work	8
3.1	Setting the stroke rate (230V motor only)	8
3.2	Select tool	8
4	Operation	11
4.1	Switching the TruTool N 500 (2A1) on and off	11
4.2	Working with TruTool N 500 (2A1)	12
4.3	Changing the cutting direction	12
4.4	Nibbling with a template	13
4.5	Producing interior cutouts	14
4.6	Overload protective device on the motor	14
5	Maintenance	15
5.1	Replacing the tool	16
5.2	Disassembling the punch	17
5.3	Installing the punch	17
5.4	Replacing the die and punch guide	17
5.5	Regrinding the punch	17
5.6	Changing the power cable	19
5.7	Replacing carbon brushes	19
6	Accessories and consumables	20
6.1	Ordering consumables	20
7	Appendix: Declaration of conformity, guarantee, replacement parts lists	21

1. Safety

1.1 General safety information

 **WARNING**



- Read all the safety information and instructions including those in the brochure also supplied.
- Failure to comply with the safety information and instructions can cause electric shock, burns and/or serious injury.
- Retain all the safety information and instructions for future use.

 **DANGER**

Electrical voltage! Risk of fatal injury due to electric shock!

- Remove the plug from the plug socket before undertaking any maintenance work on the machine.
 - Check the plug, cable and machine for damage each time before using the machine.
 - Keep the machine dry and do not operate it in damp rooms.
 - Connect the fault current (FI) circuit breaker with a maximum breaking current of 30 mA when using the electric tool outside.
 - Only use original TRUMPF accessories.
-

 **WARNING**

Damage to the machine due to improper handling.

- Wear safety glasses, hearing protection, breathing protection, protective gloves and working shoes when working.
 - Connect the plug only when the machine is switched off. Pull the power plug after use.
 - Do not carry the machine by the cable.
 - Have maintenance carried out by specialists.
-

1.2 Specific safety information for nibbler

 **DANGER**

Electrical voltage! Risk of fatal injury due to electric shock!

- Always keep the power cable behind the device and do not pull it over sharp edges.
 - Do not perform any work that may cause the machine to come into contact with hidden power lines or its own cable. Contact with a live conductor can cause metallic machine parts to become live and can lead to an electric shock.
-

 **WARNING**

Risk of injury from hot and sharp chips!

Chips exit the chip ejector at high speed.

- Use a chip bag.
-

 **WARNING**

Risk of injury from falling machinery

The entire weight of the machine must be taken up after machining the workpiece.

- Use suspension eyelet with balancer.
-

2. Description

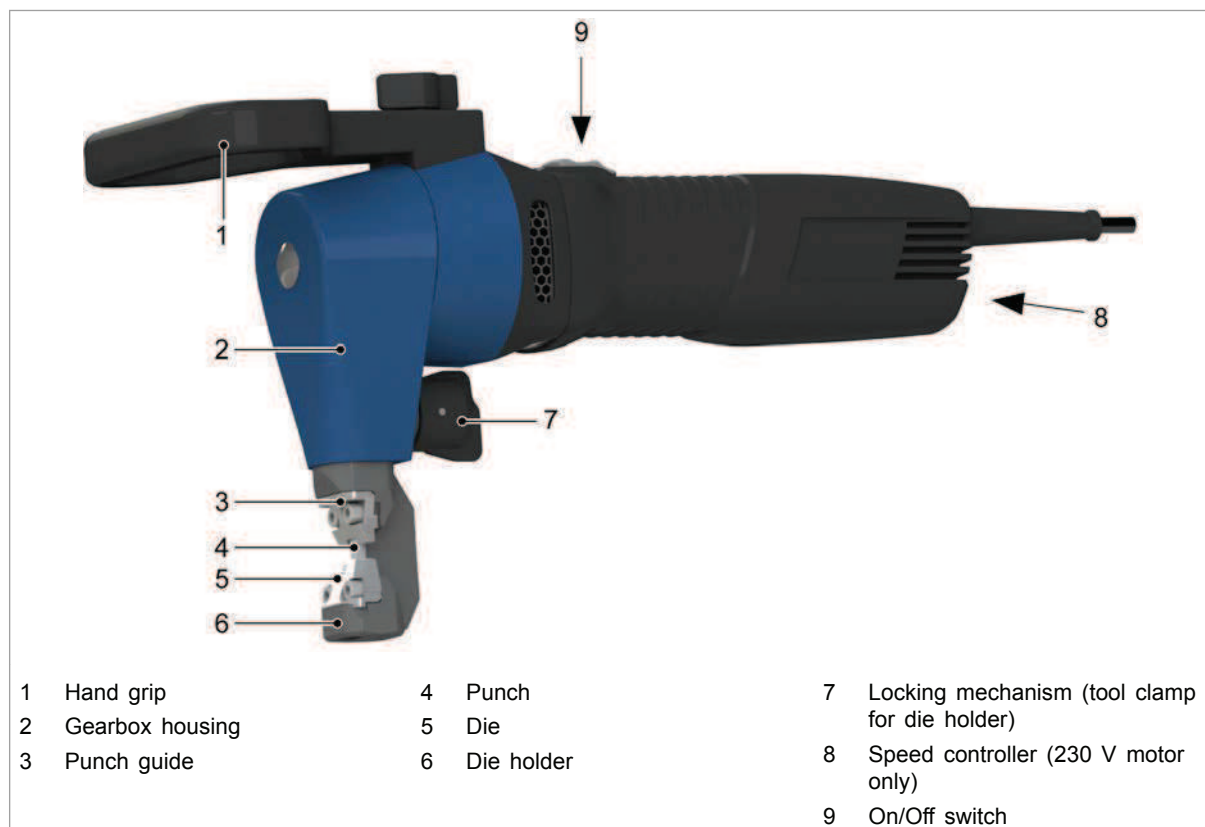

Nibbler TruTool N 500 (2A1)

Fig. 71199

2.1 Intended use





The TRUMPF Nibbler TruTool N 500 (2A1) is an electrically operated hand-held device for:

- The slitting of plate-shaped workpieces made of a punchable material such as steel, aluminum, non-ferrous heavy metals and plastic.
- The slitting of pipes and for machining of bent sheet profiles or bends; for example, for tanks, crash barrier, troughs, etc.
- The nibbling of straight or curved exterior and interior cut-outs.
- Nibbling along scribed lines or templates.

Note

The nibbling process produces cutting edges free of deformations.

2.2 Technical data



TruTool N 1000	Other countries			USA
Voltage	230 V	120 V	110 V	120 V
Frequency	50/60 Hz	50/60 Hz	50/60 Hz	50/60 Hz
Permissible material thickness: steel up to 400 N/mm²	5 mm	5 mm	5 mm	0.2 in
Permissible material thickness: steel up to 600 N/mm²	3.2 mm	3.2 mm	3.2 mm	0.125 in
Permissible material thickness: steel up to 800 N/mm²	2.5 mm	2.5 mm	2.5 mm	0.1 in
Permissible material thickness: aluminum up to 250 N/mm²	7 mm	7 mm	7 mm	0.28 in
Working speed	1.5 m/min	1.5 m/min	1.2 m/min	4.3 ft/min
Nominal power consumption	1400 W	1200 W	1140 W	1200 W
Idle stroke rate	820/min	650/min	625/min	650/min
Weight	3.9 kg			8.6 lbs
Sheet profile 90°	8 mm	8 mm	8 mm	0.31 in
Inside bending radius				
Starting hole diameter for die	41 mm	41 mm	41 mm	1.6 in
Cutting track width	8 mm	8 mm	8 mm	0.31 in
Smallest radius for curved cut-outs	90 mm	90 mm	90 mm	3.54 in
Protective insulation	II / 	II / 	II / 	II / 

Tab. 1

2.3 Icons

Note

The following symbols are important for reading and understanding the operator's manual. The correct interpretation of the symbols will help you operate the machine better and safer.

Icon	Name	Meaning
	Read operator's manual	Read the operator's manual and safety information in their entirety before starting up the machine. Closely follow the instructions given.
	Safety class II	Indicates a doubly insulated tool.
	Alternating current	Type or property of current
V	Volt	Voltage
A	Ampere	Current, current input
Hz	Hertz	Frequency (oscillations per second)
W	Watt	Power, power input

Icon	Name	Meaning
mm	Millimeters	Dimensions e.g.: material thickness, chamfer length
in	Inch	Dimensions e.g.: material thickness, chamfer length
n_0	Idle speed	Revolution speed without load
.../min	Revolutions/strokes per minute	Revolution speed, stroke rate per minute

Tab. 2

2.4 Noise and vibration information



Noise emission value may be exceeded.

- Wear hearing protection.



The vibration emission value can be exceeded!

- Select the right tools and exchange them in time in the event of wear.
- Have maintenance carried out by trained specialized technicians.
- Define additional safety measures for protecting the operator from the effect of vibrations (e. g. keep hands warm, organization of working procedures, machining at normal feed force).
- Depending on the operating conditions and state of the electric tool, the actual load might be higher or lower than the specified measured value.

Notes

- The specified vibration emission value was measured in accordance with a standardized testing procedure and can be used to compare one electric tool with another.
- The specified vibration emission value can also be applied for a provisional estimate of the vibration load.
- Times during which either the machine is switched off or running but not actually in use can considerably reduce the vibration load during the entire working period.
- Times during which the machine works independently and self-propelled do not have to be calculated.

Designation of measured value	Unit	Value according to EN 60745
Vibration emission value a_h (vector sum of three directions)	m/s ²	14.9
Uncertainty K for vibration emission value	m/s ²	2.15

Designation of measured value	Unit	Value according to EN 60745
A-class acoustic pressure level L_{PA} typically	dB (A)	84
A-class acoustic power level L_{WA} typically	dB (A)	95
Uncertainty K for noise emission value	dB	3

Tab. 3

3. Setting work

3.1 Setting the stroke rate (230V motor only)

Reduced stroke rates improve the working results:

- When processing precisely from scribed line.
- When processing radii.
- When processing steel with a strength $>400 \text{ N/mm}^2$ (better service life).



Fig. 71200

- Turn the wheel to adjust the speed.







3.2 Select tool

Select punch

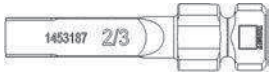
Tensile strength of the workpiece	Maximum permissible material thickness
Mild steel up to 400 N/mm^2	5 mm
Stainless steel up to 600 N/mm^2	3.2 mm
Stainless steel up to 800 N/mm^2	2.5 mm
Aluminum up to 250 N/mm^2	7 mm

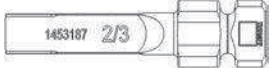
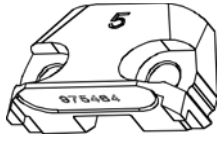
Tab. 4

Depending on the tool type, certain material thicknesses can be machined.

Material thickness mm.		Type of die	Punch type
Blank sheet	Profile sheet		
1 - 2	1	 <p>Order no.: 975468</p>	 <p>Order no.: 1453187</p>
2 - 3.2	1 - 2	 <p>Order no.: 975466</p>	 <p>Order no.: 1453187</p>
3 - 5	2 - 3	 <p>Order no.: 975464</p>	 <p>Order no.: 1451224</p>
5 - 7	3 - 5	 <p>Order no.: 975462</p>	 <p>Order no.: 1451224</p>

Selection of die and punch type

Tab. 5

1. Select a suitable punch.

Selecting a die The highest possible die must be selected.

Notes

- If strong upward and downward movements (striking) occur during the cutting process, they are caused by an unsuitable die. This results in excessive tool wear and increasing strain on the machine.
- The clearance between the sheet surface and the punch (x) must be kept as small as possible.

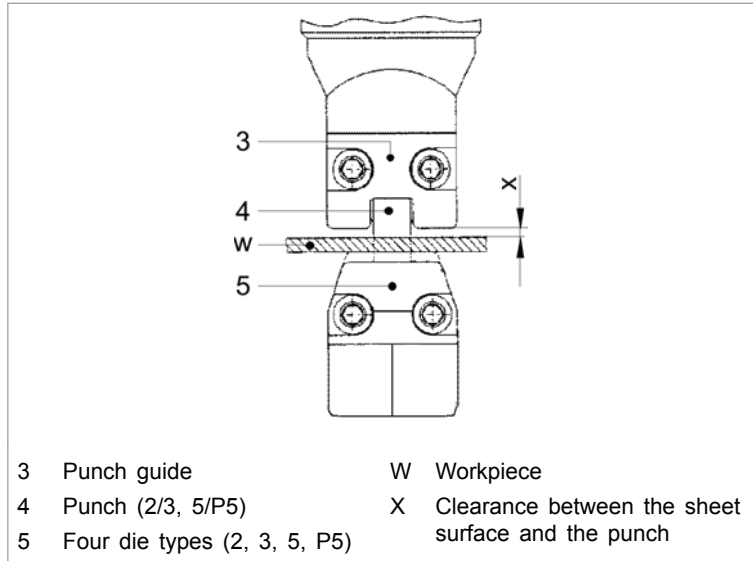

Clearance between the die and the punch guide

Fig. 71379

2. Use a die with the greatest height possible.

4. Operation

⚠ DANGER

Electrical voltage! Risk of fatal injury due to electric shock!

- Always keep the power cable behind the device and do not pull it over sharp edges.
- Do not perform any work that may cause the machine to come into contact with hidden power lines or its own cable. Contact with a live conductor can cause metallic machine parts to become live and can lead to an electric shock.

⚠ WARNING

Damage to the machine due to improper handling.

- Make sure the machine is always in a stable position when operating it.
- Never touch the tool while the machine is running.
- Always operate the machine away from your body.
- Do not operate the machine above your head.

⚠ CAUTION

Damage to property due to excessively high line voltage

Motor damage

- Check the line voltage. The power supply voltage must correspond to the information on the nameplate of the machine.
- When using an extension cord that is longer than 5 m, the cord must have a line diameter of at least 2.5 mm².

4.1 Switching the TruTool N 500 (2A1) on and off

Switching on the machine

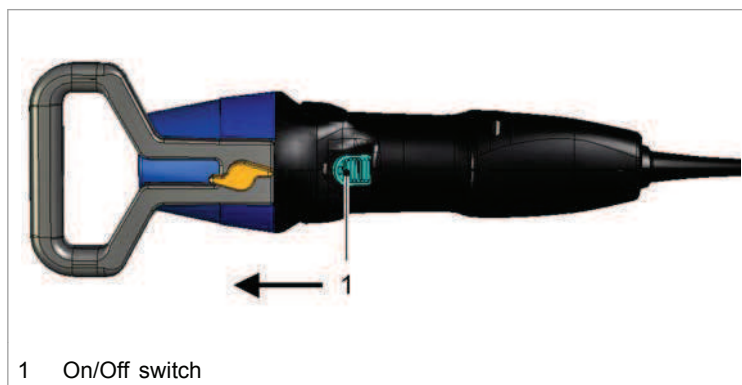

Fig. 52403

Switching off the machine

1. Push the On/Off switch forwards until it engages.
2. Press the rear part of the On/Off switch.

4.2 Working with TruTool N 500 (2A1)

Note

The cutting result will be improved and the service life of the punch lengthened if the cutting track is coated with oil before machining the workpiece.

Material	Oil
Steel	Punching and nibbling oil (0.5 l, order no. 103387)
Aluminum	Akamin, order no. 125874

Tab. 6

1. Do not move the machine towards the workpiece until full speed has been reached.
2. Edit material.
 - Process the desired cutting line.
3. If the cutting track ends in the sheet: retract the running machine a few millimeters in the direction of the already free-cut cutting track.
4. Switch off machine.

4.3 Changing the cutting direction

The tool or cutting direction can be turned 90° to the right or left or rotated by 180° in the event of confined space conditions ([see "Fig. 52772", pg. 16](#)).

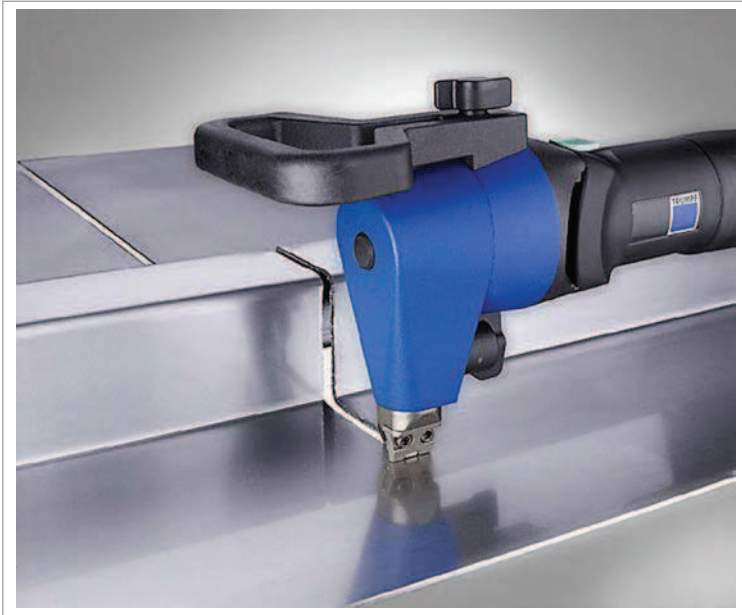

Profile cutting

Fig. 52794

1. Open the locking mechanism (8).
2. Turn the die holder (6) by 90° or 180° into the desired direction.
3. Close the locking mechanism (8).

4.4 Nibbling with a template

The following requirements must be met when nibbling with templates:

- The thickness must be at least 3 mm thick.
- There must be a clearance of 8.5 mm between the contour of the template and the contour to be nibbled out.
- Observe the minimum radius of 90 mm at the workpiece.
- The nibbler must be guided in such a way that the punch guide always remains up against the template.

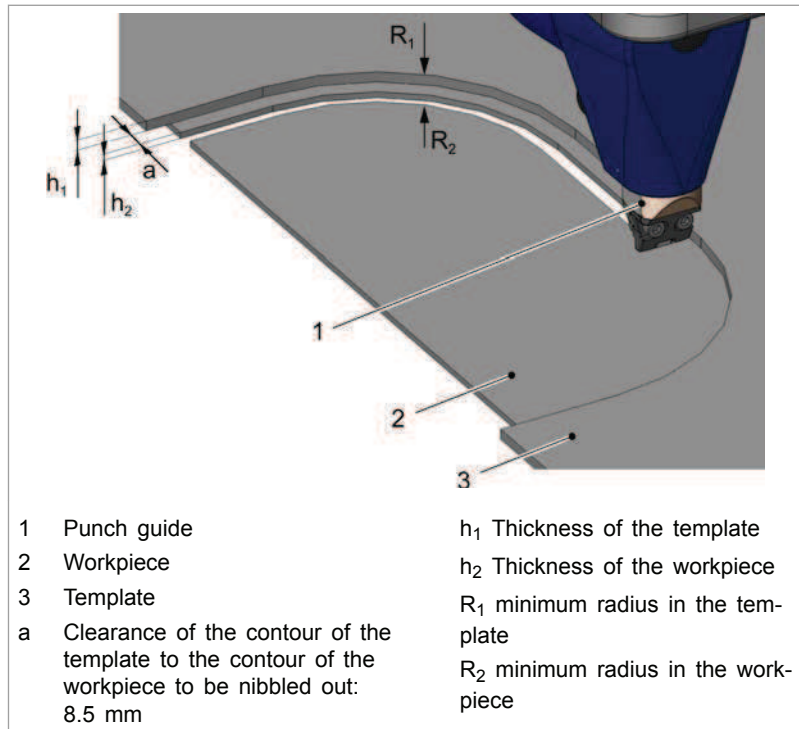

Fig. 52793

4.5 Producing interior cutouts

- Make a start bore of at least $\varnothing 41$ mm.

4.6 Overload protective device on the motor

Notes

- The appliance may switch off prematurely when affected by electromagnetic interference. The appliance will resume operation when the faults have been cleared.
- If the motor temperature is too high, the motor will switch off.

1. Allow the machine to run in idle until it has cooled down.
2. Operate the machine normally after it has cooled down.

5. Maintenance

⚠ CAUTION

Damage to property caused by blunt tools!

Machine overload.

- Check the cutting edge of the punch hourly for wear. A sharp punch provides good cutting performance and is easier on the machine.
- Change the punch in a timely manner.

⚠ WARNING

Risk of injury due to incorrect repair work

Machine does not work properly.

- Maintenance may be carried out by trained specialist technicians only.

Maintenance point	Procedure and interval	Recommended lubricants	Lubricant order number
Punch	Regrind/replace as needed.	-	-
Ventilation slots	Clean as needed	-	-
Die	Change as needed	-	-
Punches and die holders	For tool change	Lubricating grease "G1"	0344969
Gearbox and gear head	Every 300 operating hours, have a trained specialist relubricate or replace the lubricating grease.	Lubricating grease "G1"	0139440

Maintenance positions and maintenance intervals

Tab. 7

5.1 Replacing the tool

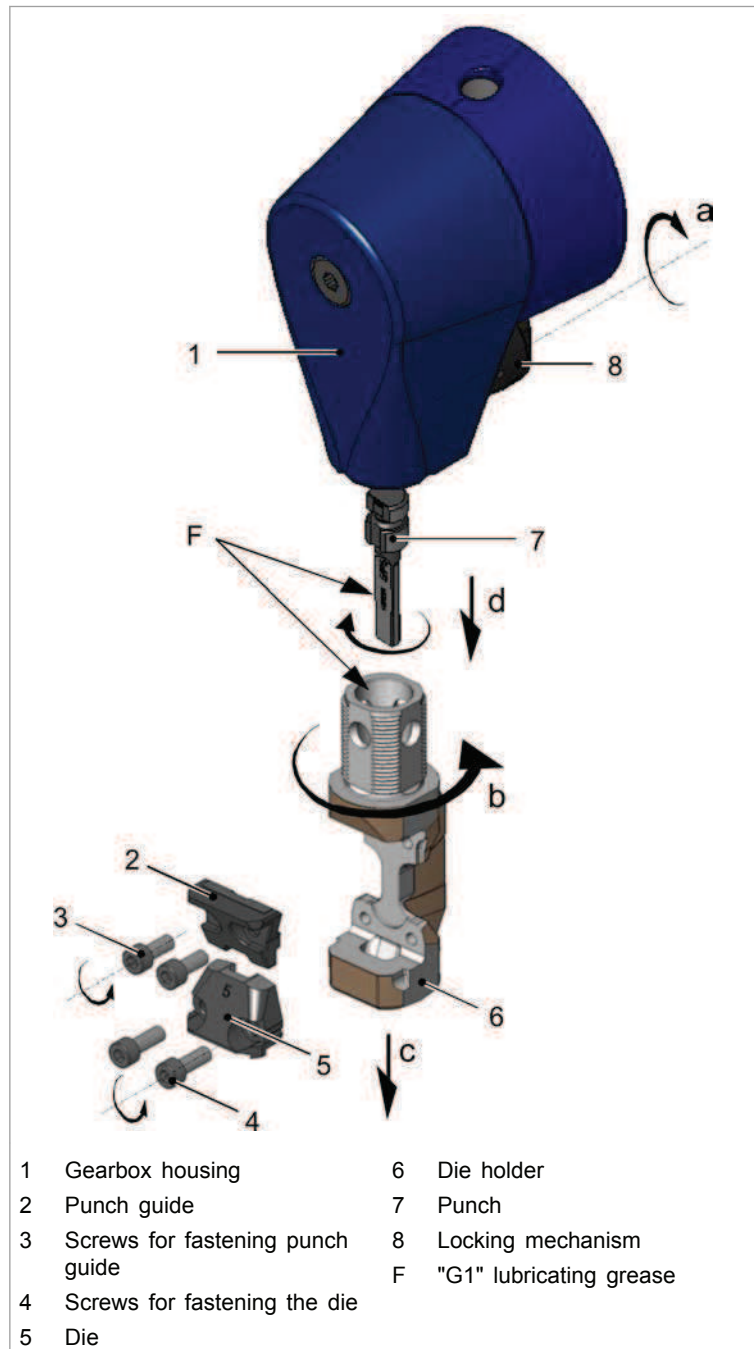

Fig. 52772

- If the punch and/or the die are dull, regrind the punch or change the tool.

5.2 Disassembling the punch

1. Open the locking mechanism (8). (a)
2. Rotate the die holder (6) by 45°. (b)
3. Pull the die holder (6) downward and out. (c)
4. Keep turning the punch (7) until you can pull it out. (d)

5.3 Installing the punch

1. Lightly lubricate the square part of the punch (7) and the bore hole at the die holder (6) with "G1" lubricating grease (order number: 0344969).
2. Turn the punch (7) to the 45° position.
3. Stick on the die holder (6).
4. Allow the locking mechanism (8) to lock into place.

5.4 Replacing the die and punch guide

1. Unscrew the screws (3 and 4) to replace the die and punch guide.
2. Clean the support areas on the die carrier (6).
 - Be sure the replacement parts are clean.
3. Lubricate the guide surfaces of the punch guide with "G1" lubricating grease (order no. 0344969).
4. When attaching the die and the punch guide, tighten the screws (torque 9 Nm). Only use original screws.

5.5 Regrinding the punch

Depending on which die it is to be used, the punch can be reground.

Note

Dies cannot be reground.

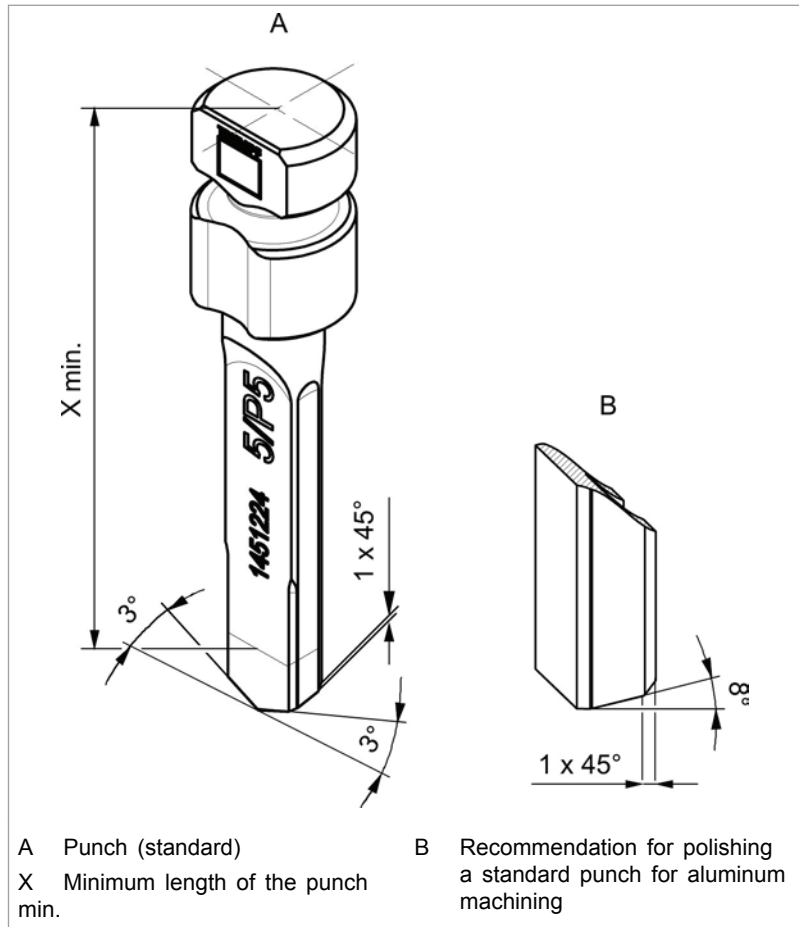

Fig. 52773

Punch	Die	Minimum length X	Regrinding reserve for punch
5/P5	P5	58.8 mm	0.5 mm
5/P5	5	56.5 mm	2.8 mm
2/3 ¹	2, 3	-	-

Tab. 8

1. Regrind the grinding surface, paying attention to good cooling.
2. Dress the cutting edge lightly with a fine oil stone.
3. Observe the minimum length (X min.) when grinding.
4. Replace shorter punch.

1 This punch type cannot be reground.

5.6 Changing the power cable

If the power cable is to be replaced, it should be procured from the manufacturer or an authorized dealer to avoid safety hazards.

Note

For TRUMPF service addresses, see www.trumpf-power-tools.com.

5.7 Replacing carbon brushes

The motor comes to a standstill whenever the carbon brushes are worn out.

Note

For TRUMPF service addresses, see www.trumpf-power-tools.com.

- Change the carbon brushes.

6. Accessories and consumables

Name	Scope of delivery	Consumables	Accessories	Order number
Handle, complete	X	-	-	0974659
Allen key DIN 911-4	X	-	-	0067849
Lubricating grease "G1" (40 g)	X	-	-	0344969
Case	X	-	-	0982540
Punch 5/P5	-	X	-	1451224
Punch 2/3	-	X	-	1453187
Die 2	-	X	-	0975468
Die3	-	X	-	0975466
Die5	-	X	-	0975464
Die P5	-	X	-	0975462
Punching and nibbling oil for steel (0.5 l)	-	-	X	0103387
Punching and nibbling oil for aluminum (1 l)	-	-	X	0125874
Suspension eyelet	-	-	X	0097208
Chip bag	-	-	X	0103557
Operator's manual	X	-	-	1893445
Safety information, other countries	X	-	-	125699
Safety information (red document), USA	X	-	-	1239438

Tab. 9

6.1 Ordering consumables

Note

The following data must be specified in order to ensure that parts are delivered correctly and without delay.

1. Specify the order number.
2. Enter further order data:
 - Voltage data
 - Quantity
 - Machine type
3. Specify the complete shipping information:
 - Correct address.
 - Desired delivery type (e.g. air mail, courier, express mail, ordinary freight, parcel post).

Note

For TRUMPF service addresses, see www.trumpf-powertools.com.

4. Send the order to the TRUMPF representative office.

**7. Appendix: Declaration of conformity,
guarantee, replacement parts lists**

