

# EQ100 Assembly & Parts List

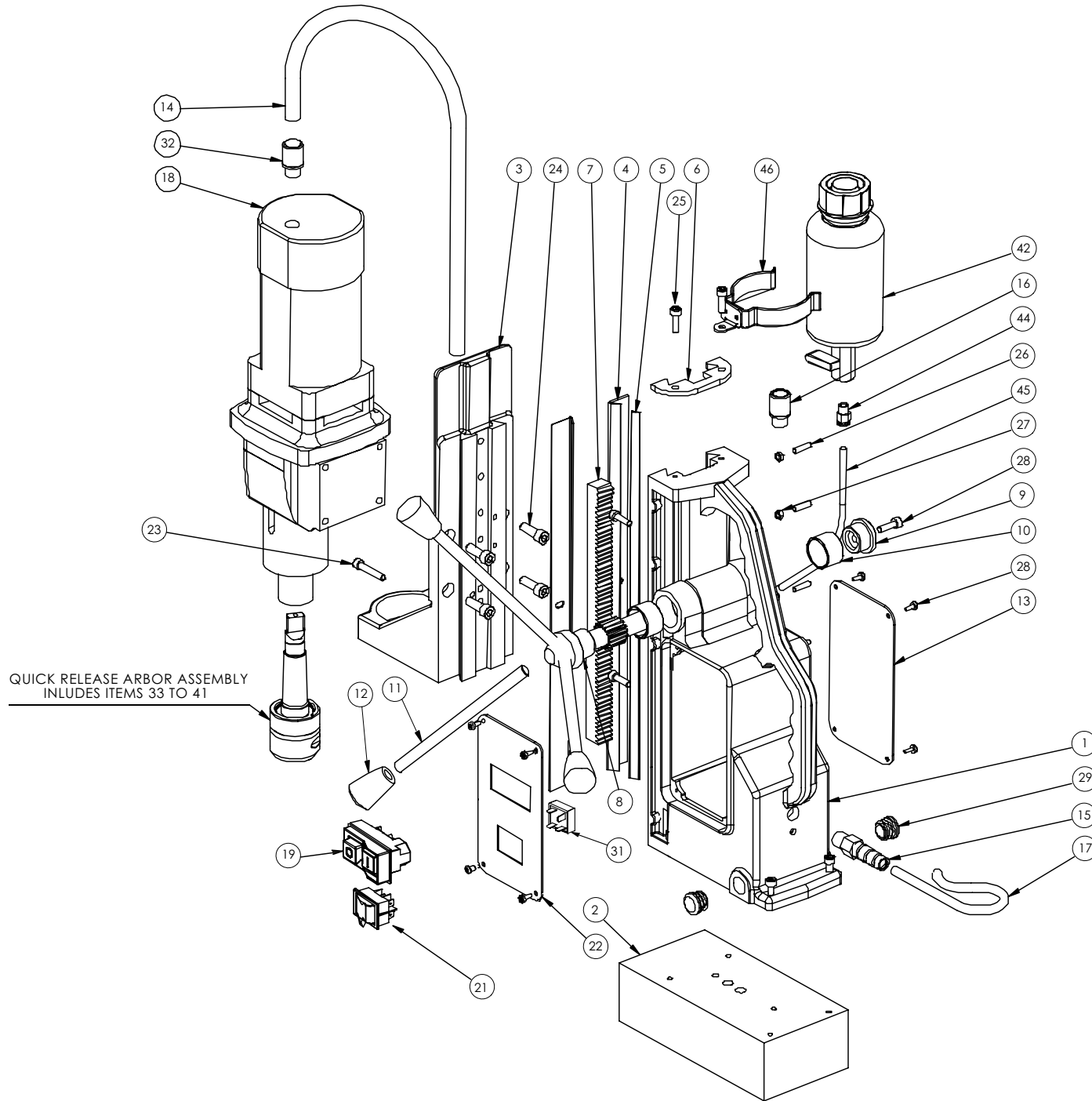

ITEM NO	PART NO	DESCRIPTION	QTY
1	M005BLU	MT50 BODY (CAPRI BLUE)	1
2	M0033	MAGNET BASE (LARGE)	1
3	20355	EIBENSTOCK CRADLE	1
4	M0103	BRASS RAIL (MT50)	2
5	M0442	G.F.S. (MT50)	1
6	M0813	TOP PLATE (MAGTRON DOVETAIL)	1
7	M0833	RACK (MT50)	1
8	M0042	PINION - MAGTRON (LARGE)	1
9	M0071	PINION END CAP (SHALLOW)	1
10	M0081	BUSH (PINION)	2
11	20346	HANDLE (12mm LARGE)	3
12	10082	HANDLE KNOB (12mm KNOCK ON)	3
13	NWP-03	WARNING PLATE (LARGE)	1
14	M0443	CONDUIT	1
15	10231	M16 STRAIN RELIEF CABLE GLAND	1
16	40026	M16 PUSH FIT GLAND	1
17	10237-1	CABLE YELLOW (110V)	1
18	EIB03	EIBENSTOCK UNI111 DRILL - 110V	1
18	EIB04	EIBENSTOCK UNI111 DRILL - 240V	1
19	NCP001	DRILL STOP/START SWITCH 110V	1
19	NCP002	DRILL STOP/START SWITCH 240V	1
20	M0401	BRIDGE RECTIFIER	1
21	NCP006	MAGNET SWITCH (NCP)	1
22	NCP14	NCP SWITCH PLATE LARGE	1
23	SC630CAP	M6 x 30 CAP HEAD SCREW	1
24	SC816CAP	M8 x 16 CAP HEAD SCREW	4
25	SC616CAP	M6 x 16 CAP HEAD SCREW	5
26	10085A	M5 x 25 SOCKET SET SCREW	6
27	10085B	M5 NYLON NUT	6
28	SC410BH	M4 x 10 BUTTON HEAD SCREW	8
29	*****	SWIVEL PIN BLANKING BUNG	2
32	40025	PG9 PUSH FIT GLAND	1
33	ARBQR03-A	EIBENSTOCK Q/R UNI3 ARBOR BODY	1
34	10205A	ARBOR EJECTION PLUG (M/TAPER)	1
35	SPR101	ARBOR SPRING (M/TAPER)	1
36	ARBQR-02	QUICK RELEASE ARBOR COLLAR	1
37	ARBQR-03	QUICK REL ARBOR LOCK SHOE	1
38	ARBQR-04	Q/RELEASE COLLAR SPRING	1
39	ARBQR-05	QUICK REL ARBOR TOR SPRING	2
40	ARBQR-06	20MM O/D X 4MM NITRILE O RING	1
41	CCP-38V	38OD V INTERNAL CIRCLIP	1
42	30046	LARGE OIL CUP ASSEMBLY	1
44	50015A	1/8" BSP - 6MM PUSH FIT CONNEC	2
45	50013A	6mm OIL PIPE (OIL FEED ASSY)	1
46	10076C	OIL CUP RETAINING CLIP COMPLETE	1

# EQ100S Assembly & Parts List

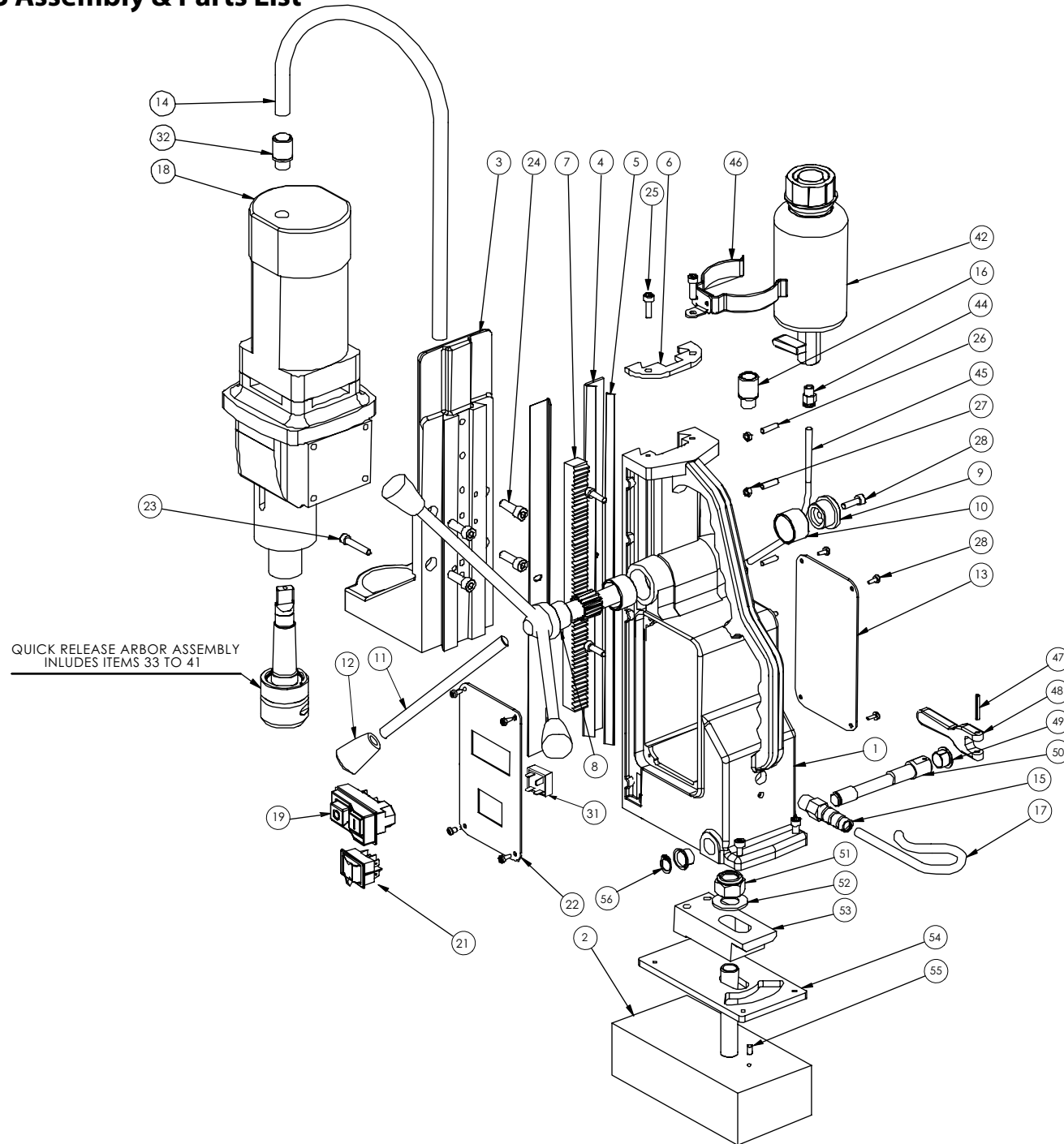

ITEM NO	PART NO	DESCRIPTION	QTY
1	M0005BLU	MT50 BODY (CAPRI BLUE)	1
2	M0036	MAGNET BASE (LARGE) SWIVEL	1
3	20355	EIBENSTOCK CRADLE	1
4	M0103	BRASS RAIL (MT50)	2
5	M0442	G.F.S. (MT50)	1
6	M0813	TOP PLATE (MAGTRON DOVETAIL)	1
7	M0833	RACK (MT50)	1
8	M0042	PINION - MAGTRON (LARGE)	1
9	M0071	PINION END CAP (SHALLOW)	1
10	M0081	BUSH (PINION)	2
11	20346	HANDLE (12mm LARGE)	3
12	10082	HANDLE KNOB (12mm KNOCK ON)	3
13	NWP-03	WARNING PLATE (LARGE)	1
14	M0443	CONDUIT	1
15	10231	M16 STRAIN RELIEF CABLE GLAND	1
16	40026	M16 PUSH FIT GLAND	1
17	10237-1	CABLE YELLOW (110V)	
18	EIB03	EIBENSTOCK UNI111 DRILL - 110V	1
18	EIB04	EIBENSTOCK UNI111 DRILL - 240V	1
19	NCP001	DRILL STOP/START SWITCH 110V	1
19	NCP002	DRILL STOP/START SWITCH 240V	1
20	M0401	BRIDGE RECTIFIER	1
21	NCP006	MAGNET SWITCH (NCP)	1
22	NCP14	NCP SWITCH PLATE LARGE	1
23	SC630CAP	M6 x 30 CAP HEAD SCREW	1
24	SC816CAP	M8 x 16 CAP HEAD SCREW	4
25	SC616CAP	M6 x 16 CAP HEAD SCREW	5
26	10085A	M5 x 25 SOCKET SET SCREW	6
27	10085B	M5 NYLOK NUT	6
28	SC410BH	M4 x 10 BUTTON HEAD SCREW	8
29	*****	SWIVEL PIN BLANKING BUNG	2
32	40025	PG9 PUSH FIT GLAND	1
33	ARBQR03-A	EIBENSTOCK Q/R UNI3 ARBOR BODY	1
34	10205A	ARBOR EJECTION PLUG (M/TAPER)	1
35	SPRI01	ARBOR SPRING (M/TAPER)	1
36	ARBQR-02	QUICK RELEASE ARBOR COLLAR	1
37	ARBQR-03	QUICK REL ARBOR LOCK SHOE	1
38	ARBQR-04	Q/RELEASE COLLAR SPRING	1
39	ARBQR-05	QUICK REL ARBOR TOR SPRING	2
40	ARBQR-06	20MM O/D X 4MM NITRILE O RING	1
41	CCP-38V	38OD V INTERNAL CIRCLIP	1
42	30046	LARGE OIL CUP ASSEMBLY	1
44	50015A	1/8" BSP - 6MM PUSH FIT CONNEC	2
45	50013A	6mm OIL PIPE (OIL FEED ASSY)	1
46	10076C	OIL CUP RETAINING CLIP COMPLETE	1
47	SELPIN430	4x30 SELOC PIN	1
48	MO701	SWIVEL CAM HANDLE	1
49	MO741	SWIVEL CAM PIN BUSH	2
50	MO721	SWIVEL CAM PIN	1
51	MO621	NYLOC NUT SWIVEL BASE	1
52	MO641	WASHER SWIVEL BASE	1
53	MO661	SWIVEL CAM BLOCK	1
54	MO911	SWIVEL PLATE	1
55	*****	M6x16 SET SCREW	1
56	CCPX-14	CAM PIN CIRCLIP	1

# EQ100 Mechanical Switchplate (NCP Panel ) 120v

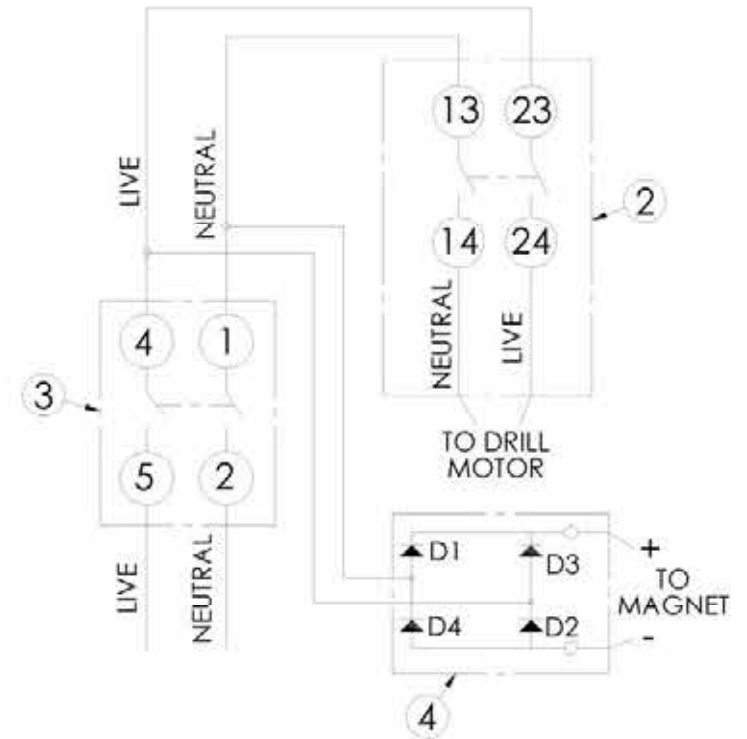
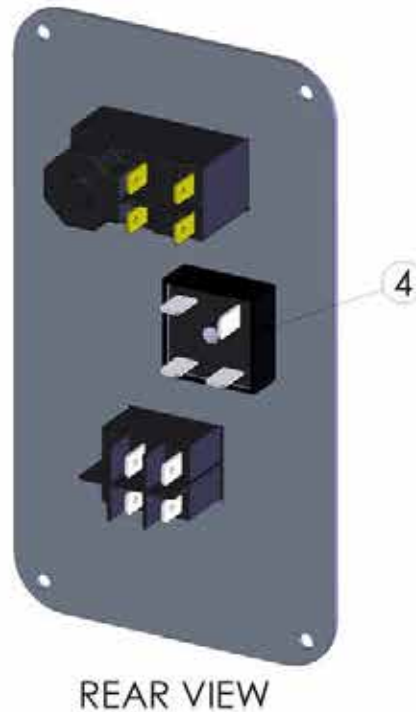
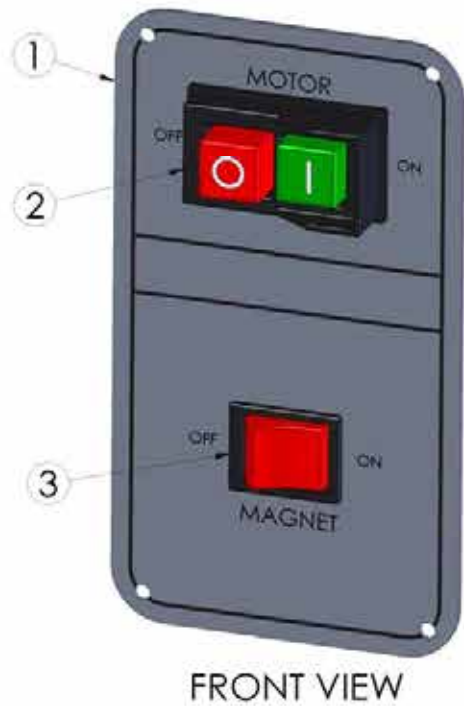

ITEM NO.	QTY.	PART NO.	DESCRIPTION
1	1	NCP013	NCP BLANK SWITCH PLATE - LARGE
2	1	NCP001	DRILL STOP/START SWITCH-120v
3	1	NCP006	MAGNET SWITCH NCP PANEL
4	1	M0401	25A-BRIDGE RECTIFIER

NOTES:  
1. ITEM 4 TO BE BONDED TO REAR OF PLATE

# EQ100 Mechanical Switchplate (NCP Panel ) 240v

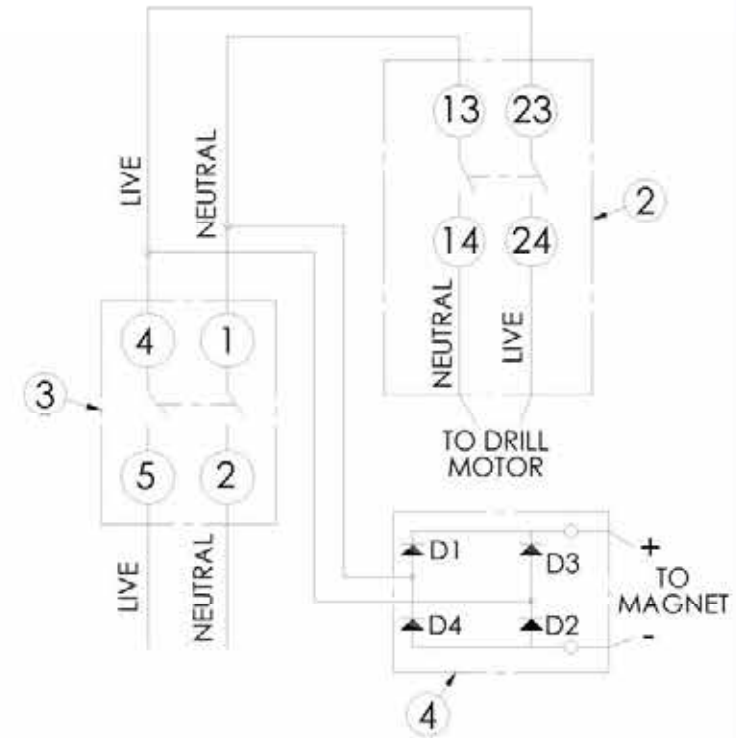
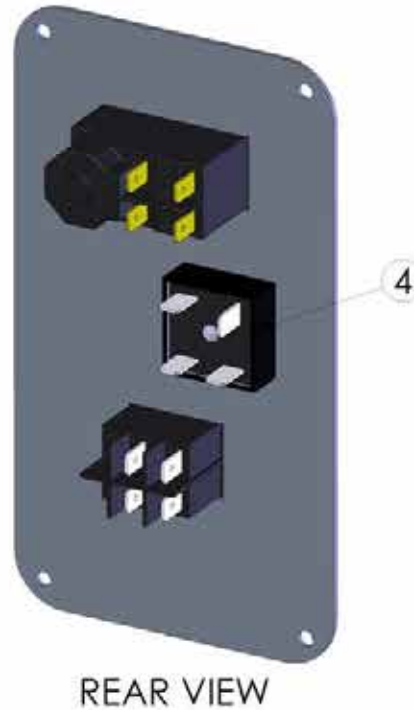
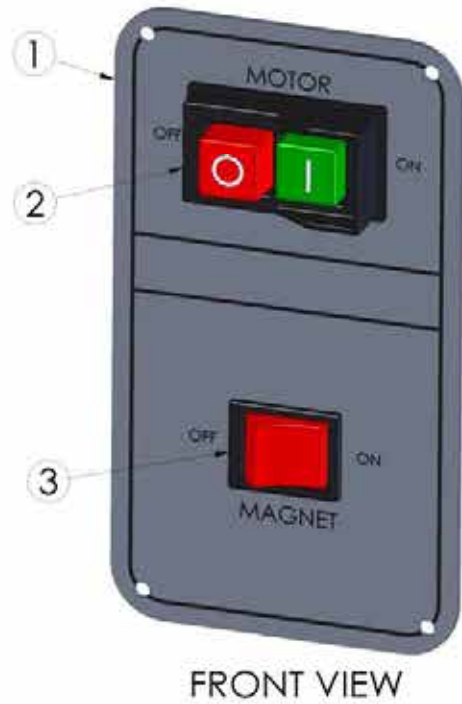

ITEM NO.	QTY.	PART NO.	DESCRIPTION
1	1	NCP013	NCP BLANK SWITCH PLATE - LARGE
2	1	NCP002	DRILL STOP/START SWITCH-230v
3	1	NCP006	MAGNET SWITCH-NCP PANEL
4	1	M0401	25A-BRIDGE RECTIFIER

NOTES:  
1. ITEM 4 TO BE BONDED TO REAR OF PLATE

## EQ100 Electronic Switchplate (Panel P) Dual voltage

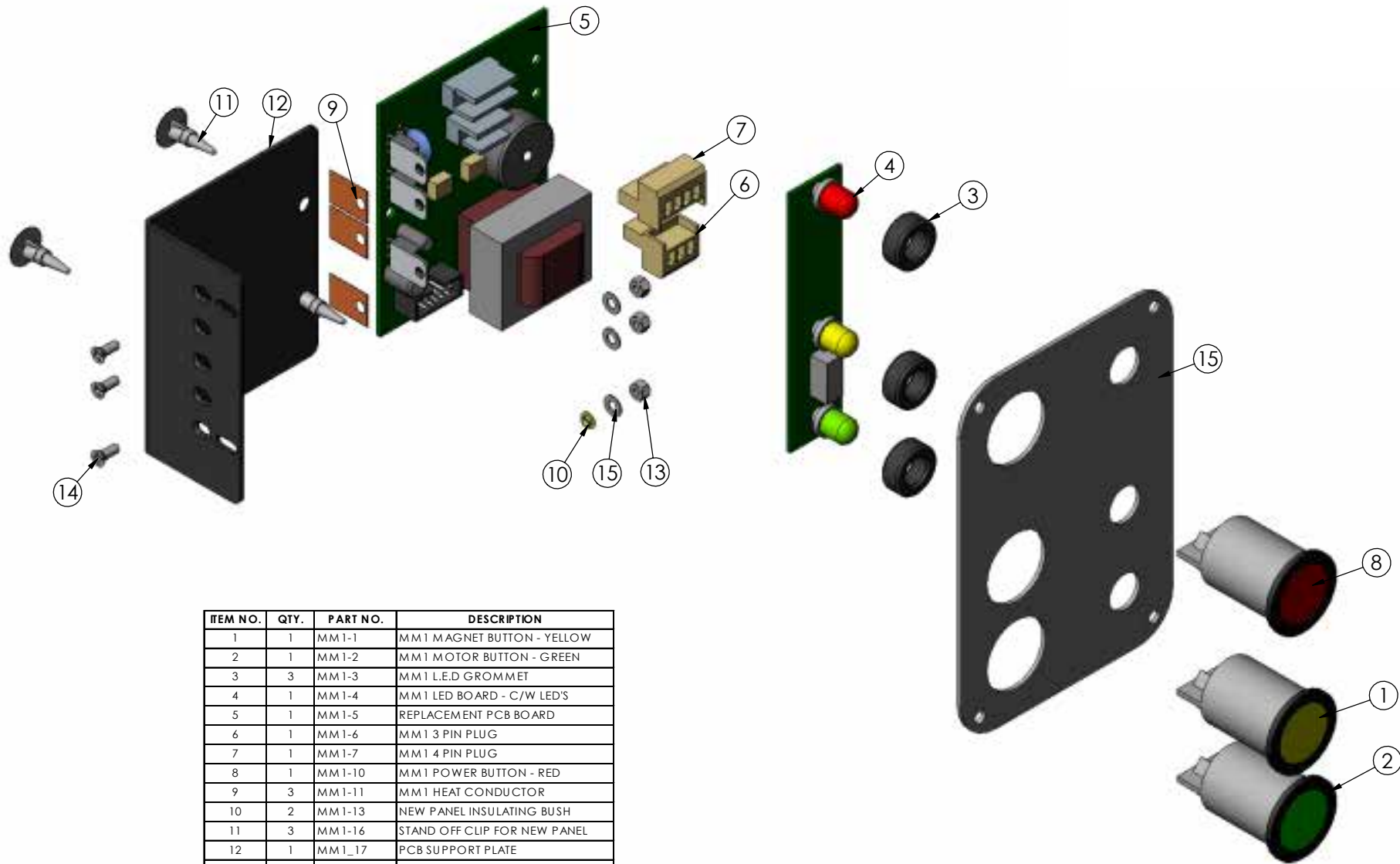

ITEM NO.	QTY.	PART NO.	DESCRIPTION
1	1	MM1-1	MM1 MAGNET BUTTON - YELLOW
2	1	MM1-2	MM1 MOTOR BUTTON - GREEN
3	3	MM1-3	MM1 L.E.D GROMMET
4	1	MM1-4	MM1 LED BOARD - C/W LED'S
5	1	MM1-5	REPLACEMENT PCB BOARD
6	1	MM1-6	MM1 3 PIN PLUG
7	1	MM1-7	MM1 4 PIN PLUG
8	1	MM1-10	MM1 POWER BUTTON - RED
9	3	MM1-11	MM1 HEAT CONDUCTOR
10	2	MM1-13	NEW PANEL INSULATING BUSH
11	3	MM1-16	STAND OFF CLIP FOR NEW PANEL
12	1	MM1_17	PCB SUPPORT PLATE
13	3	NUT-M3	M3 NYLOC NUT
14	3	SC36CSK-X	M3 X 6 C'SINK CROSS HEAD SCREW
15	1	-	PANEL FACIA PLATE

**EQ100 Electronic Switchplate (Panel P) Wiring Diagram (110v)**

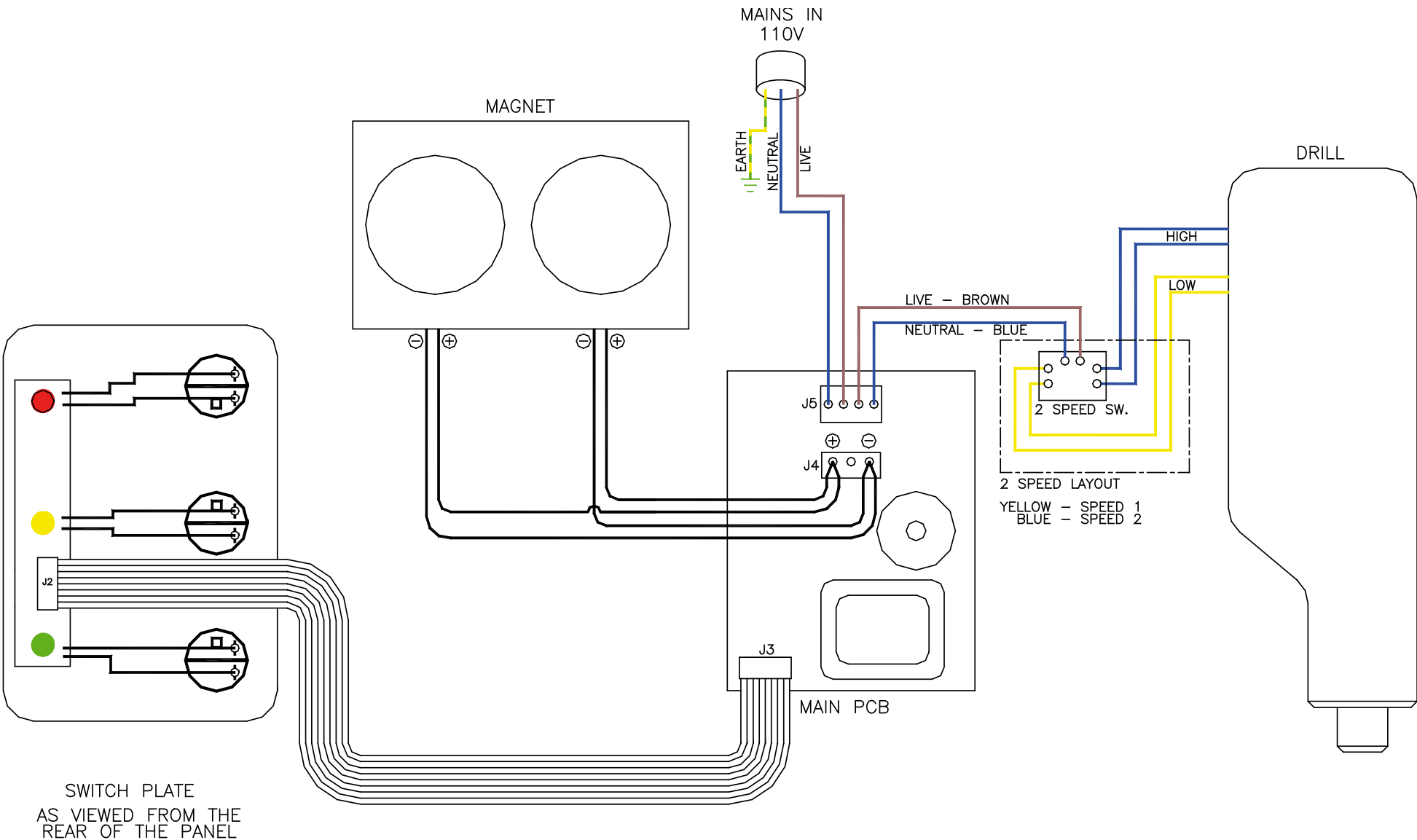

**EQ100 Electronic Switchplate (Panel P) Wiring Diagram (240v)**

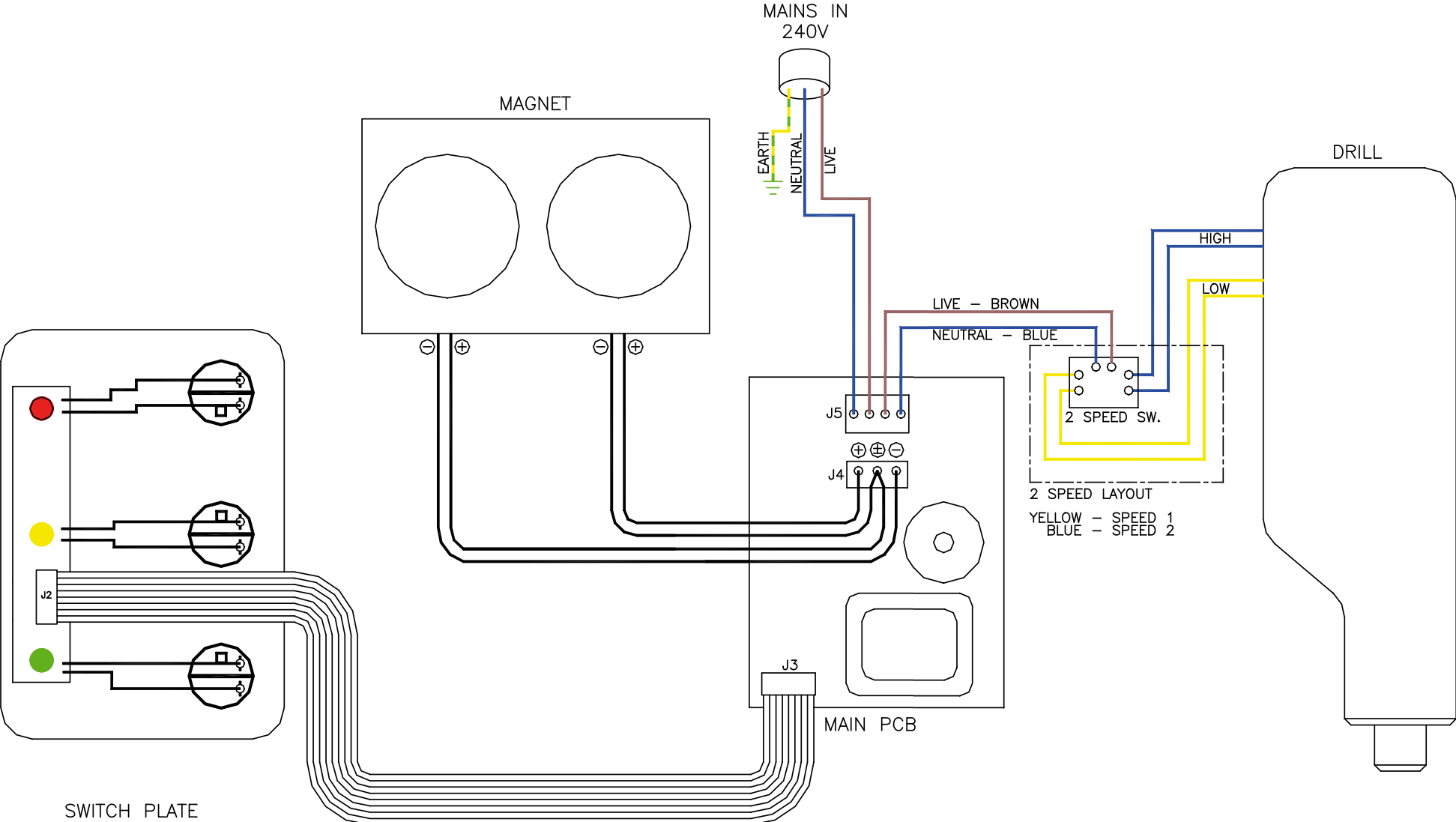

SWITCH PLATE  
AS VIEWED FROM THE  
REAR OF THE PANEL

2 SPEED LAYOUT  
YELLOW - SPEED 1  
BLUE - SPEED 2